

This Horizontal & vertical table is so designed as to permit machining operations at a higher dimension. The base can be used in a vertical position to enabling to carry out center work.

### Dimensions

Order No.	TABLE DIMENSION										BASE DIMENSION						T-SLOT WIDTH	TYPE OF SLOT	T-BOLT SIZE	CENTER BORE	Weight		Gear ratio	
	TABLE		HIGHT		OVERALL LENGTH		OVERALL HEIGHT		CENTER HEIGHT		BASE LENGTH		BASE WIDTH		BASE HEIGHT						Kg	lb		
	Inch	mm	Inch	mm	Inch	mm	Inch	mm	Inch	mm	Inch	mm	Inch	mm	Inch	mm								
110239	4.5/16	110	2.3/8	63	7.7/8	200	2.7/8	72	3.1/4	82.1	4.1/2	114	1.1/2	138	1.3/4	46	7/16	11	⊗	M8	MT-2	7	15.4	90:1
110241	5	125	2.3/4	70	9	228	2.7/8	72	3.5/8	92.1	5	127	7	178	1.3/4	46	7/16	11	⊕	M8	MT-2	8	17.6	90:1
110242	6	150	3	75	10.1/4	258	3	77	4	102.7	6	151	8	204	2	50	7/16	11	⊕	M8	MT-2	11.5	25.3	90:1
110243	8	200	4	101	13	330	4	103	5.1/4	135	8	203	10.1/2	264	2.1/2	64	9/16	14	⊕	M10	MT-3	25	55	90:1
110244	10	250	4.1/4	108	15	382	4.1/4	110	6.1/2	163.5	10	250	13	328	2.7/8	72	9/16	14	⊗	M10	MT-3	35	77	90:1

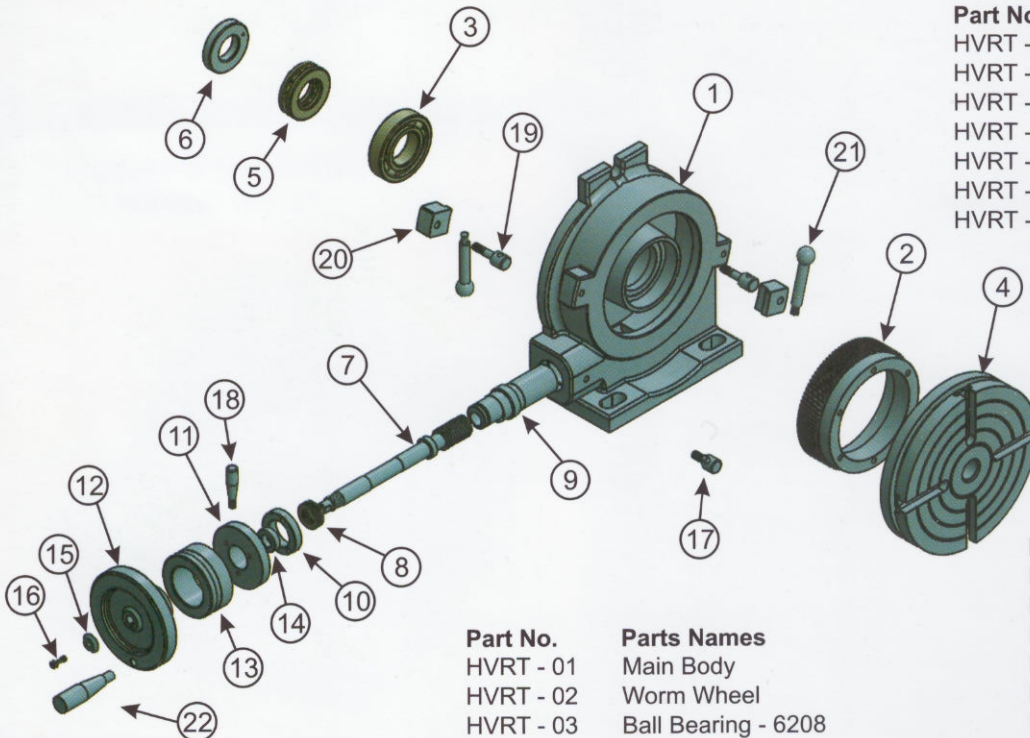
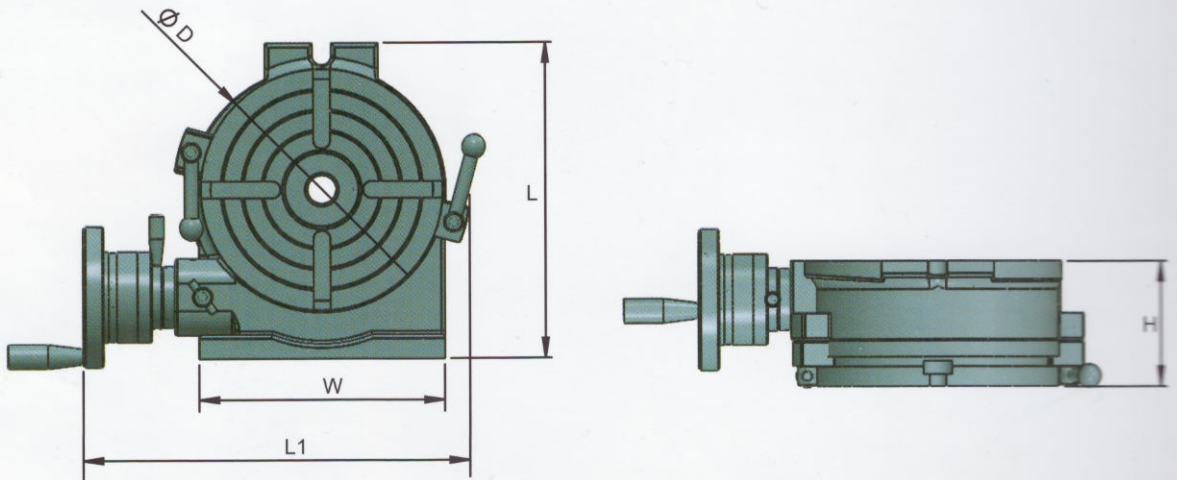

Part No.	Parts Names
HVRT - 07	Worm
HVRT - 08	Thrust Ball Bearing - 51103
HVRT - 09	Worm Metal
HVRT - 10	Collar
HVRT - 11	Vernier Ring
HVRT - 12	Hand Wheel
HVRT - 13	Micro Collar

Part No.	Parts Names
HVRT - 01	Main Body
HVRT - 02	Worm Wheel
HVRT - 03	Ball Bearing - 6208
HVRT - 04	Table
HVRT - 05	Thrust Ball Bearing - 51207
HVRT - 06	Threaded Collar

Part No.	Parts Names
HVRT - 14	Worm Ring
HVRT - 15	Washer
HVRT - 16	Cap Screw
HVRT - 17	Metal Setting Screw
HVRT - 18	Vernier Ring Handle
HVRT - 19	Clamp Screw
HVRT - 20	Clamp Piece
HVRT - 21	Clamp Handle
HVRT - 22	Handle

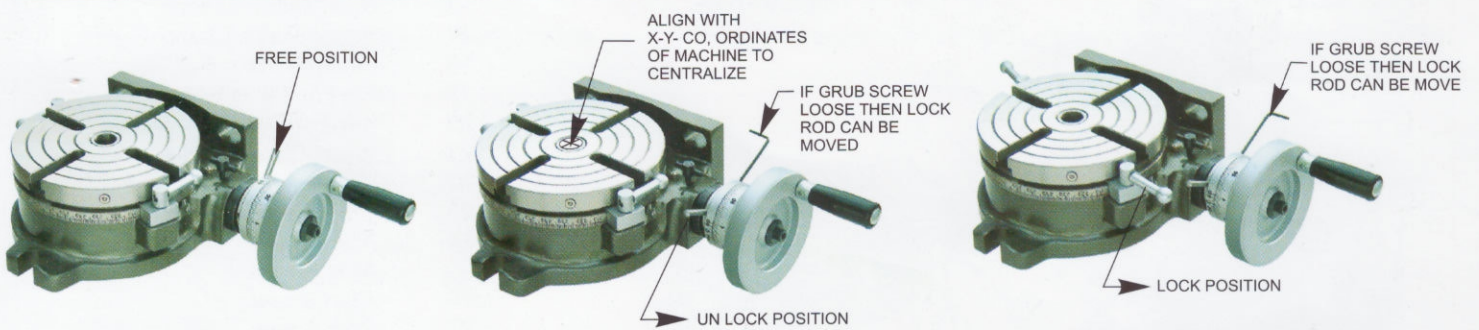
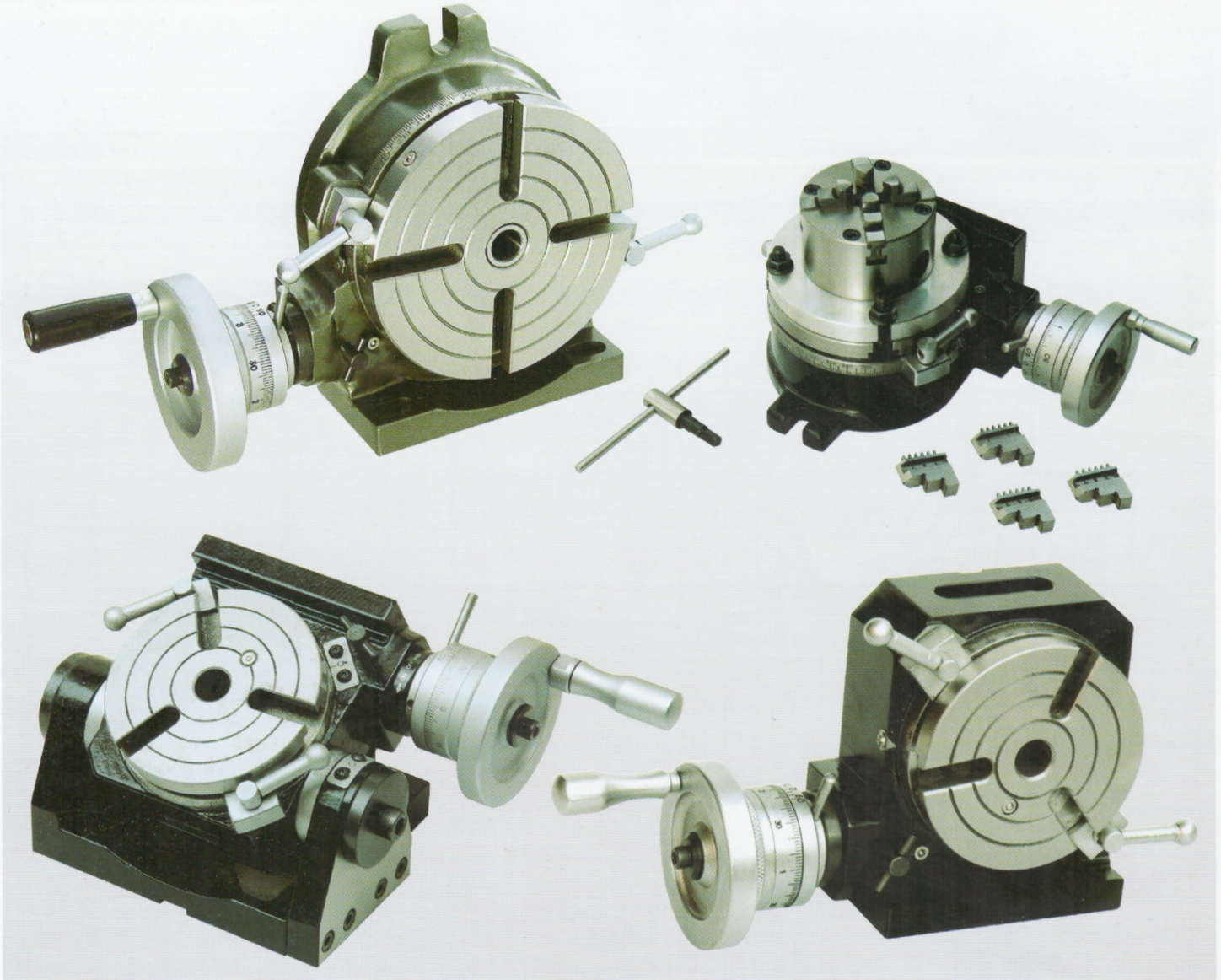

## ALIGNMENT

Aligning the center of the Rotary Table to the spindle is essential for achieving quality results. Position the spindle over center of the Rotary Table and touch all four sides (inside outside) until all sides read "0" on the indicator (to rotate the Spindle and not the Rotary Table).

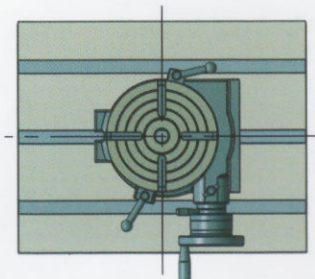

### Dimensions

Order No.	TABLE DIMENSION					BASE DIMENSION										TYPE OF SLOT	T-BOLT SIZE	CENTER BORE	TILT BODY HEIGHT		Weight		Gear ratio	
	TABLE		HIGHT		OVERALL LENGTH		OVERALL HEIGHT		CENTER HEIGHT		BASE LENGTH		BASE WIDTH		BODY HEIGHT				Inch	mm	Kg	lb		
	Inch	mm	Inch	mm	Inch	mm	Inch	mm	Inch	mm	Inch	mm	Inch	mm	Inch				mm					
111325	4.5/16	110	2.3/8	63	9.3/4	248	4.9/16	116	3.1/4	82	6.3/4	172	5.5/8	142	2.7/8	72	⊕	M8	MT-2	6/7/16	164	12	26.4	90:1
111335	6	150	2.13/16	81	11.1/2	291	5	124	4.1/8	105	8.7/16	214	7.1/16	180	3.1/8	80	⊕	M8	MT-2	8	204	20	44	90:1

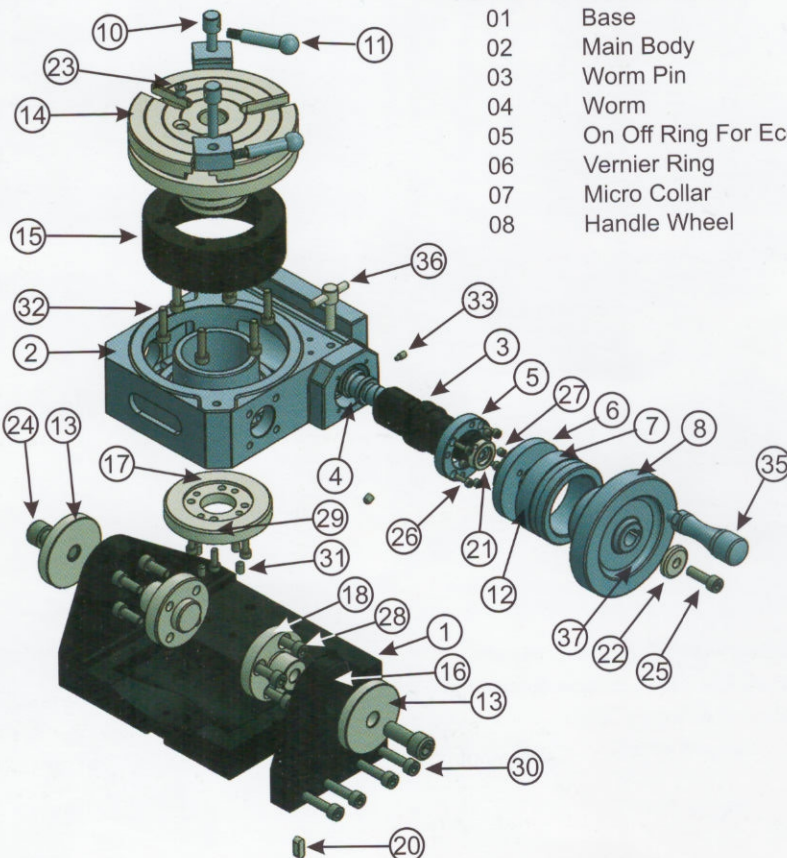
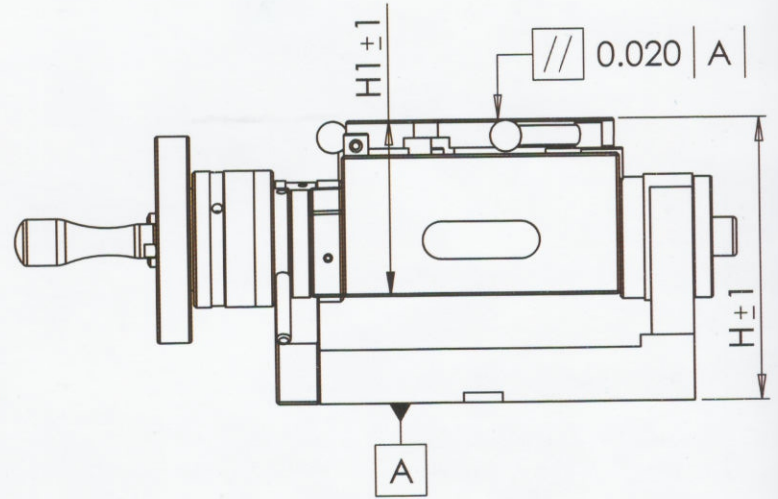
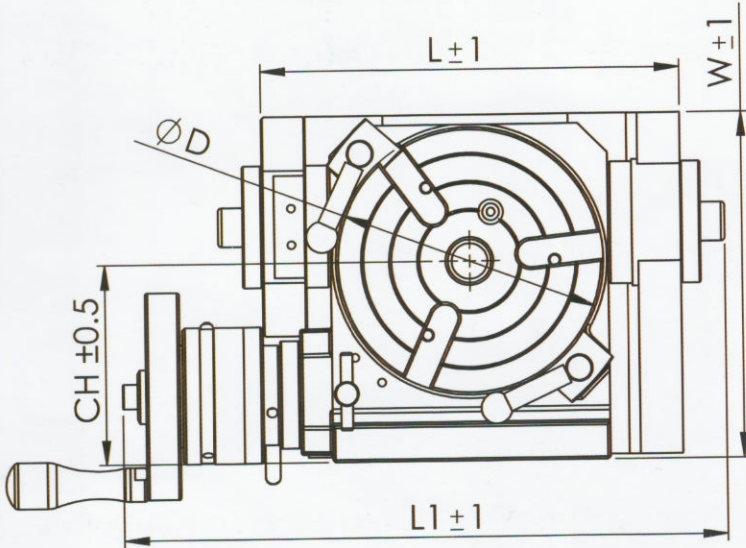

- | Part No. | Parts Names                   |
|----------|-------------------------------|
| 01       | Base                          |
| 02       | Main Body                     |
| 03       | Worm Pin                      |
| 04       | Worm                          |
| 05       | On Off Ring For Eccentric Pin |
| 06       | Vernier Ring                  |
| 07       | Micro Collar                  |
| 08       | Handle Wheel                  |

- | Part No. | Parts Names                     |
|----------|---------------------------------|
| 09       | Clamp For Table                 |
| 10       | Clamp Screw 1/4" X 20"          |
| 11       | Clamping Handle                 |
| 12       | Vernier Ring Handle             |
| 13       | Side Clamping Piece             |
| 14       | Table                           |
| 15       | Helix Gear Part                 |
| 16       | Side Mounted Piece              |
| 17       | Bottom Table Clamp. Plate       |
| 18       | Pin With Mark. For Tilting Body |
| 19       | Pin For Tilting Body            |
| 20       | Key For Base                    |
| 21       | Worm Clamping Nut               |
| 22       | Washer                          |
| 23       | 1/4" Oil Nipple                 |
| 24       | Allen Screw                     |
| 25       | Allen Screw                     |
| 26       | Allen Screw                     |
| 27       | Grub Screw                      |
| 28       | Allen Screw                     |
| 29       | Allen Screw                     |
| 30       | Allen Screw                     |
| 31       | Grub Screw                      |
| 32       | Allen Screw                     |
| 33       | Grub Screw                      |
| 34       | Allen Screw                     |
| 35       | Handle                          |
| 36       | Spl. Bolt 1/4" X 20"            |
| 37       | Key For Handle                  |

## OPERATING INSTRUCTION AND FUNCTION OF EACH UNIT

1. The worm gear is 90:1.
  - One turn of the handle moves the table by  $4^\circ$
  - Micro - collar is graduated in steps of 1 min.
  - Vernier scale makes settings down to 10 seconds possible 110243, 110244 (20 seconds for 110239, 110241, 110242)
2. Dividing of 2 to 100 can be carried out quickly and accurately by attaching a Dividing Mechanism.
3. Center work can also be carried out by using the base in the vertical Position in conjunction with a tailstock.

## THERE ARE THREE METHODS OF SETTING POSITIONS USING A ROTARY TABLE

1. Use the degree scale on the outer edge of the table (scale reading = 1 degree)
  - a To use the degree scale on the table top, disengage the worm by unlocking the T screw and rotating the pin on the worm collar clockwise. The table can be rotated by hand and can be locked in any position using the lock clamps.
2. Use the degree handwheel (scale on handwheel = degrees and minutes)
  - a To use the handwheel, unlock or loosen the T screw and rotate the pin on the worm collar anti-clockwise and when the worm has engaged, lock or tighten the T screw. If the worm collar will not rotate easily, it may be necessary to rotate the handwheel while keeping pressure on the pin so the worm will mesh or engage. The hand wheel is divided into degrees and minutes eg: 4 degrees per revolution or ratio of 90:1. The minute divisions on the handwheel can be further divided into 20 seconds using the vernier scale.
3. Use the index method (use index plates and refer index table)
  - a To use the index method first refer to the index table to select the index plate with the correct holes on the circle. (See Index table located on the Page-8 back of this manual)
  - b To use the index plates, the hand wheel must be removed by loosening the centre retaining screw and washer.
  - c Mount the appropriate index plate with the correct number of holes to the collar with 3 screws.
  - d Next fit the sector arms (the brass pieces) and adjust the sector arms for the correct number of holes. Holes are counted after the pin or first hole. So for six holes, sector arms are actually set for seven holes ie; pin + 6 holes.
  - e Fit the retaining washer in the groove in front of the sector arms.
  - f Fit the crank with the spring loaded handle, adjusting so the plunger lines up with the correct circle of holes. Tighten with the screw and washer that held the handwheel.
  - g To index, rotate the handle the correct number of full turns and then using the sector arms to measure the number of holes. After the handle is locked in, rotate the arms ready for the next cycle or index.

Eg: For 21 tooth gear or 21 divisions, Use the 21 hole plate. Set the sector arms for 6 holes then rotate the handle 4 full turns plus 6 holes. If in doubt, have a practice run

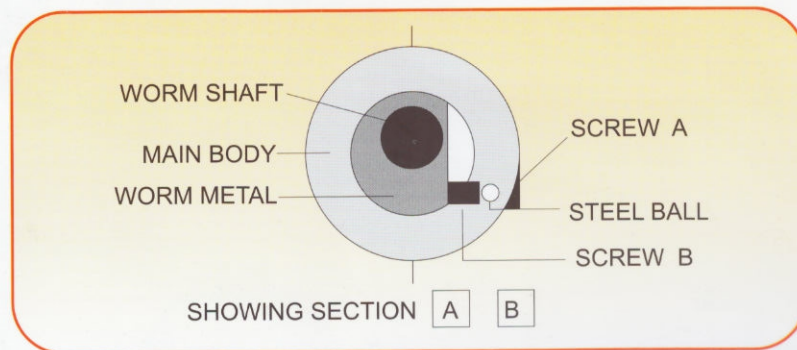

1. **Adjusting Mesh of worm Gear:-** Loosen the metal clamp handle and turn the switch metal clockwise until it touches the stopper. The worm gear has now been disengaged. Turn it counterclockwise until it touches the stopper, the worm and gear wheel will engage. Tighten the metal clamp handle after engagement. An additional adjustment can be obtained by removing the screw **A** and steel ball and turning the inner screw **B** counter clock-wise so bringing the worm in closer engagement with the gear wheel. Turning clock-wise brings the worm away from the wheel. After adjustment insert the steel ball and tighten screw **A**
2. **Axial Adjustment of Worm shaft:-** When axial slack occurs gear adjustment is carried out by tightening the inside worm shaft nut after the handle, vernier ring and switch metal have been removed. After adjustment, lock the nut on the shaft by means of the set screw. (The ROTARY TABLE has an adjustment, nut, which can be used after removal of the handle.)