



[www.insize.com](http://www.insize.com)

INSIZE



**IST-WS SERIES  
SHORT HANDLE DIGITAL TORQUE WRENCH  
OPERATION MANUAL**



**Attention**

- ◆ Don't use the wrench as a hammer.
- ◆ Don't use the wrench in water.
- ◆ Over-torque (110% max. torque range) could cause damage or lose accuracy. If **Err** is appeared, that means this wrench has ever been applied more than 110% torque of maximum range.
- ◆ The accuracy of the readout is guaranteed from 20% to 100% of maximum range.

**Description**

**① Function features :**

- ◆ Clockwise and anticlockwise operation.
- ◆ Unit: N.m, in.lb, ft.lb, kg.cm.
- ◆ Peak and track working mode.
- ◆ Target torque value can be set, with audible and visible alarm: 4 green LED light on and buzzer sounds when target torque value is approached. 2 red LED light on and buzzer sounds when target torque value is reached.
- ◆ Power off automatically in 5 minutes without any operations.
- ◆ Non-slip grip handle.
- ◆ With record if the wrench fell in the water.
- ◆ With overload record (once the torque reaches 110% of the maximum range).
- ◆ With certificate of inspection.

**② Structure:**

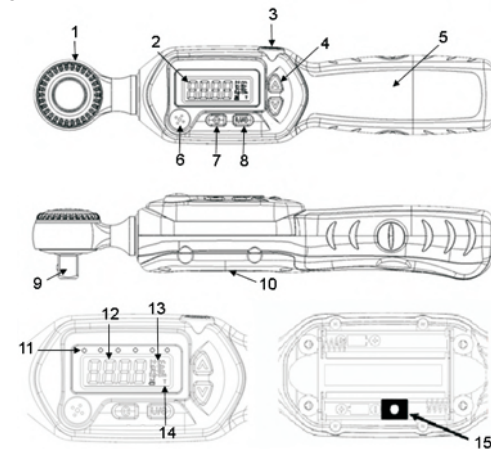

- 1 Reversible ratchet head 2 LCD display 3 Calibration port 4 Up/Down button  
 5 Handle 6 Buzzer 7 Power on/Clear button 8 Unit/Setting button 9 Ratchet drive  
 10 Battery cover 11 LED indicator 12 Torque value 13 Unit  
 14 P (Peak mode) /T (Track mode) 15 Water indicator

**Operation**

**1** Inserting the batteries:

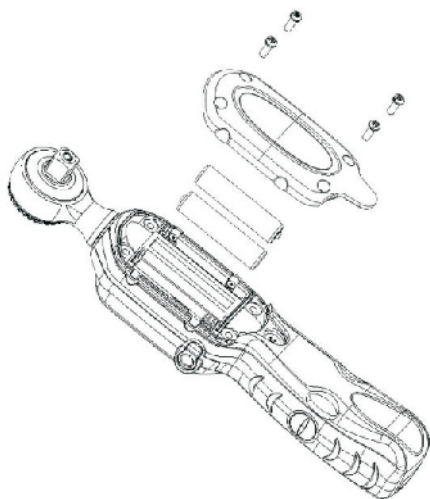

Open the battery cover  
Insert two AAA batteries  
Close the battery cover

**2** Turn on and initialize:

- ◆ Press **C** to turn on.
- ◆ After turn on the wrench, press **C** to initialize.

**Note:** When turning on and initializing the wrench, don't exert force.

**3** Reset the wrench:

- ◆ If the wrench working abnormal, press **C** and up button at the same time for resetting the wrench.

**4** Low battery indicator:

- ◆ When the battery is low, the screen displaying the sign as shown and it will power off in a few seconds.



**5** Select the unit:

In the initial interface, press **U/S** to select the unit.



**6** Set torque value:

In the initial interface, press up and down button.

**Note:** Target torque value can be set, with audible and visible alarm: 4 green LED light on and buzzer sounds when target torque value is approached. 2 red LED light on and buzzer sounds when target torque value is reached.

**7** Peak & track mode:

- ◆ In the initial interface, long press **U/S** then appearing the following picture.



- ◆ Press up and down button to select peak or track mode. Peak mode means after used the wrench the screen will display and hold the peak value; Track mode means the screen will display current value.



Peak mode



Track mode

- ◆ After selected, press **U/S** until back to the initial interface.



## Maintenance

- 1 Do not shake violently or drop wrench.
- 2 Do not leave this wrench in any place exposed to excessive heat, humidity, dust, sand, magnetic or direct sunlight.
- 3 Do not use organic solvents, such as alcohol or paint thinner when cleaning the wrench.
- 4 When the wrench is not used for an extended period of time, remove the battery, apply antirust oil on the exposed metal part, put the wrench in box for storing.

←INSIZE→