



Magnifying Fluorescent Work Light Beam



WITH 5X LENSE



VHL-30TEB
BENCH TYPE



VHL-30MEB



3 Diopter auxiliary lens
(optional)

VHL-30LEB

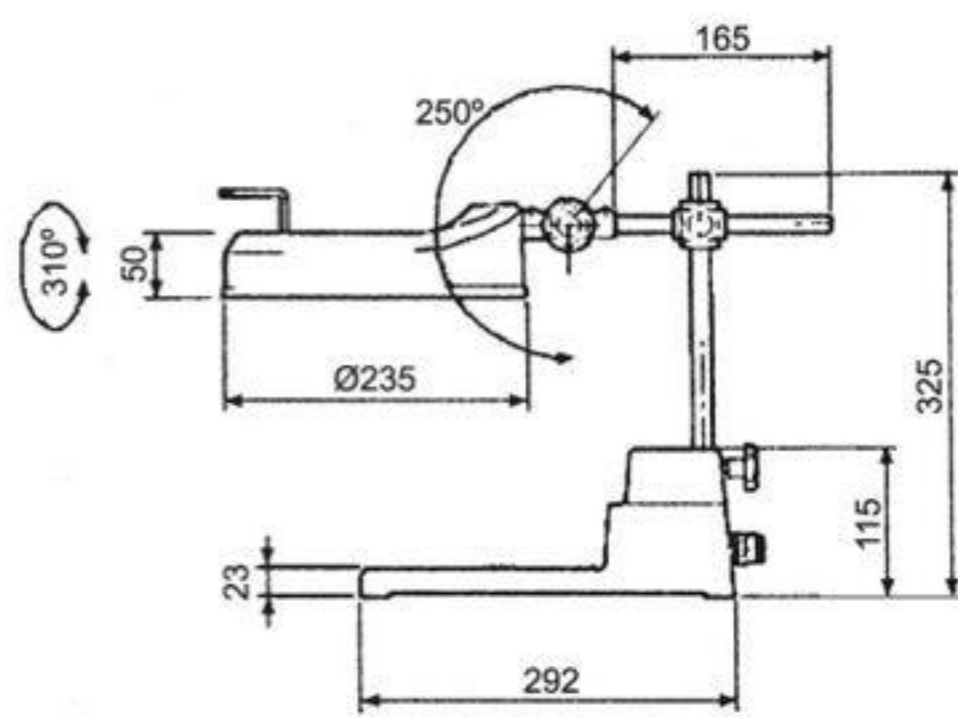

VHL-30TEB BENCH TYPE

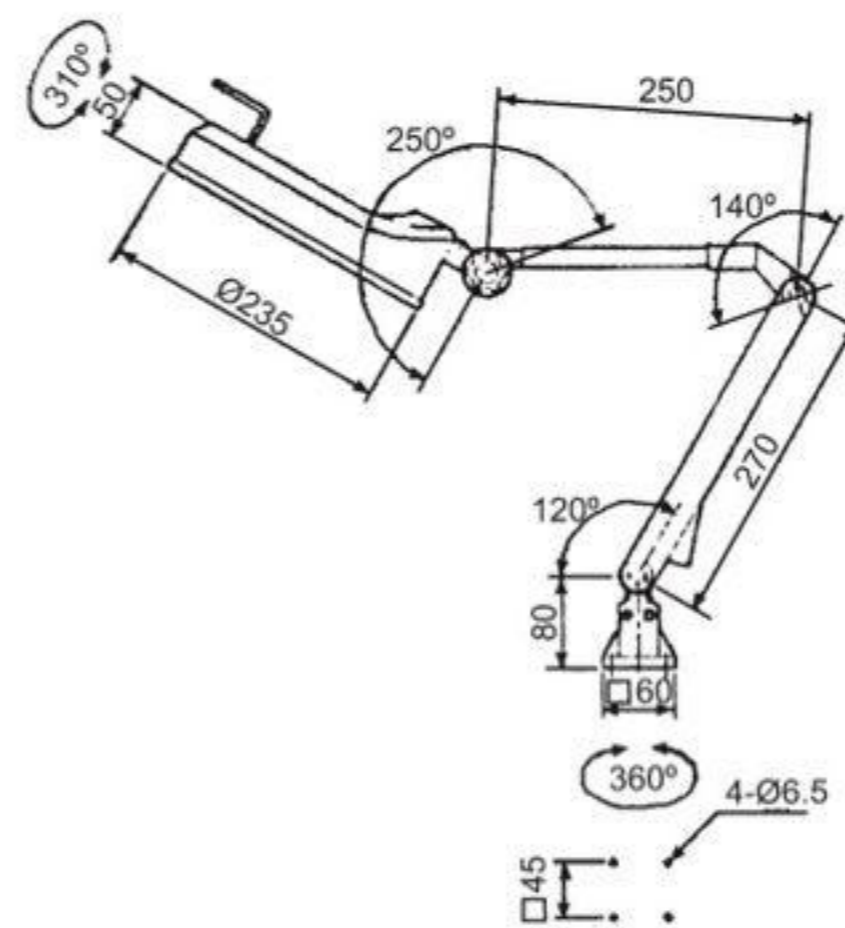

VHL-30MEB MEDIUM ARM

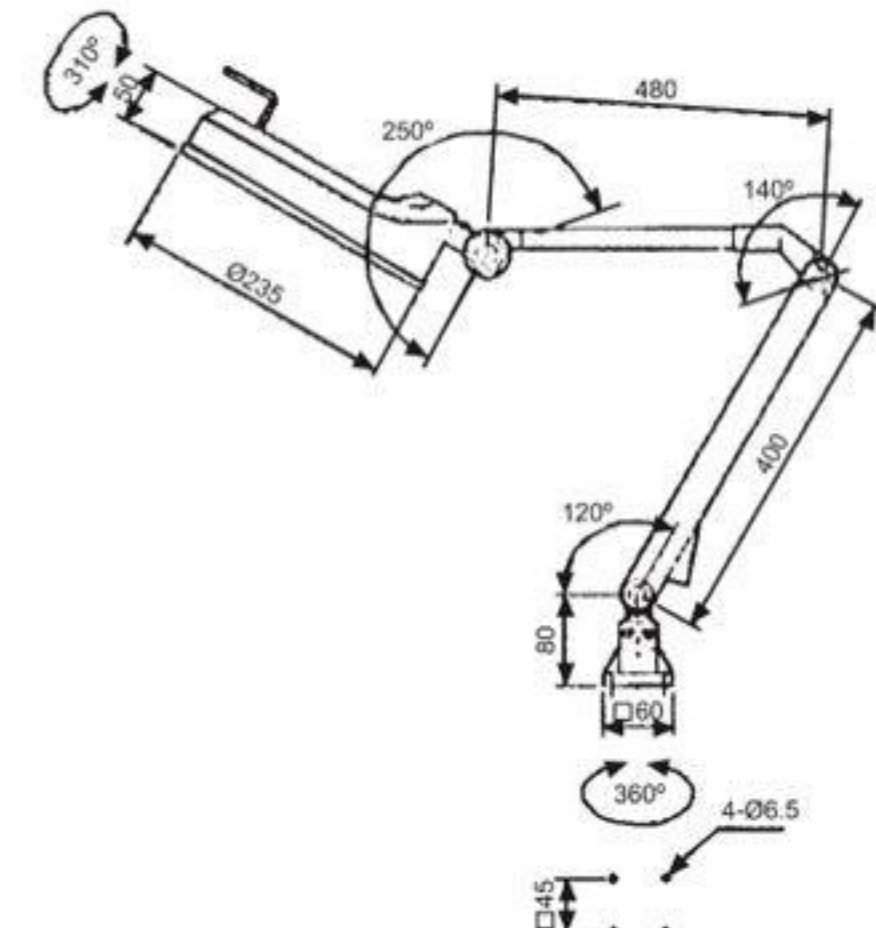

VHL-30LEB LONG ARM

VHL-30TEB

- Bench type model.
- Constructed with a wide base for placing object, allowing it especially suited for inspection lighting.
- Electronic ballast is built in arm.
- Accepts 22 watt fluorescent tube.
- ※ 110V, or 220V operation. Supplied single voltage only. Specify desired voltage when ordering.
- Furnished with 1.8 meter cord with plug. Extended cord length is available when required.

Designed with a magnifier lens on luminaire head giving 5 Diopter of magnification 2.25x than actual object. The fluorescent lighting provides day light effect without flash.

●OPTIONAL●

ORDER NO. VHL-3X
3 Diopter magnifier lense=1.75X



●OPTION

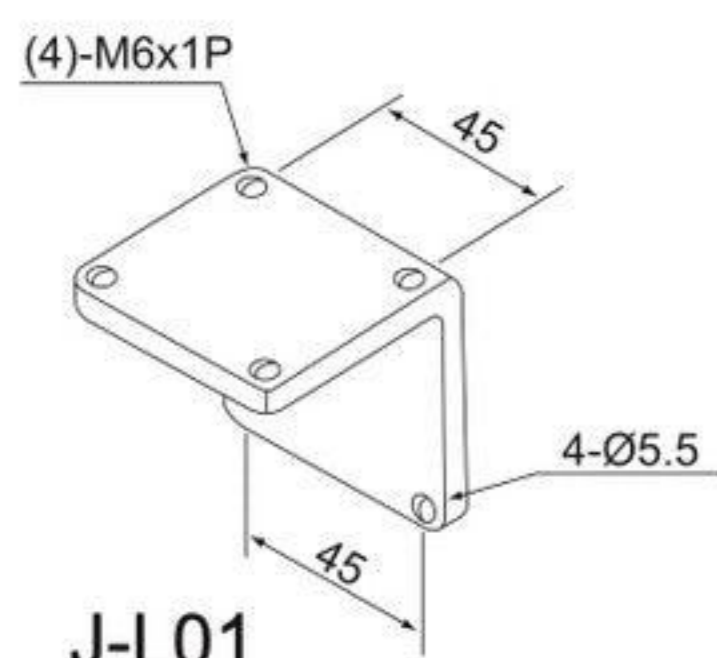

J-L01

MOUNTING ANGLE
PLATE

●STANDARD ACC.

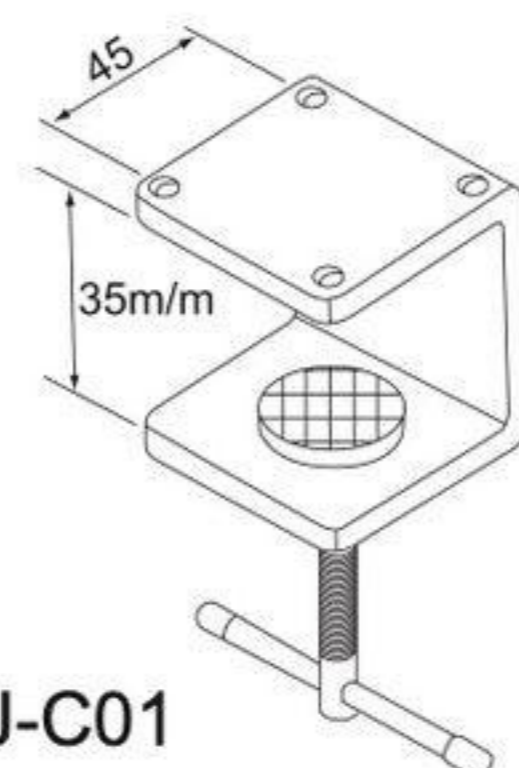

J-C01

MOUNTING CLAMP

VHL-30 MEB

- Medium arm model.
- Electronic ballast is built in arm.
- Accepts 22 watt fluorescent tube.
- 110V, or 220V operation. Supplied single voltage only. specify desired voltage when ordering.
- Furnished with 1.8 meter cord with plug. Extended cord length is available when required.

VHL-30 LEB

- Long arm model.
- Electronic ballast is built in arm.
- Accepts 22 watt fluorescent tube.
- 110V, or 220V operation. Supplied single voltage only. Specify desired voltage when ordering.
- Furnished with 1.8 meter cord with plug. Extended cord length is available when required.

ORDER NO.	WEIGHT (kg)	CODE NO.
VHL-30TEB	3.5	1025-060
VHL-30MEB	2.9	1025-062
VHL-30LEB	2.9	1025-063
J-L01	0.6	1025-014
VHL-3X	0.3	1025-065

- All VHL-XXXEB work lights are with 5 Diopter magnifier lense, The MAX.=5+3=8 Diopter