



Universal Tilting Hydraulic Machine Vise



NEW

PATENT

- JAM PROOF
- HYDRO LIMIT PROOF.
- SCREW SHAFT BROKEN PROOF

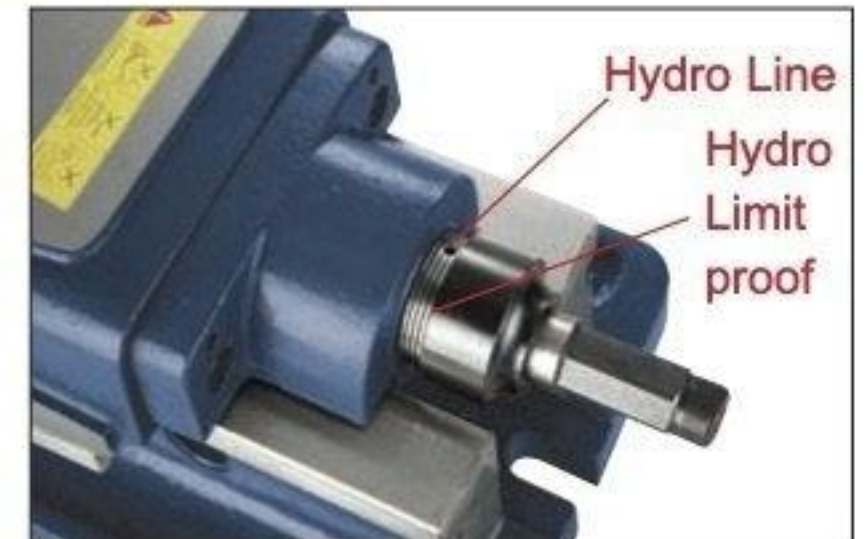

Hydraulic controller:
provide stable pressure,
Hydro indexer. Protect the hydro system.
Hydro limit proof reference scale.
Screw shaft broken proof.

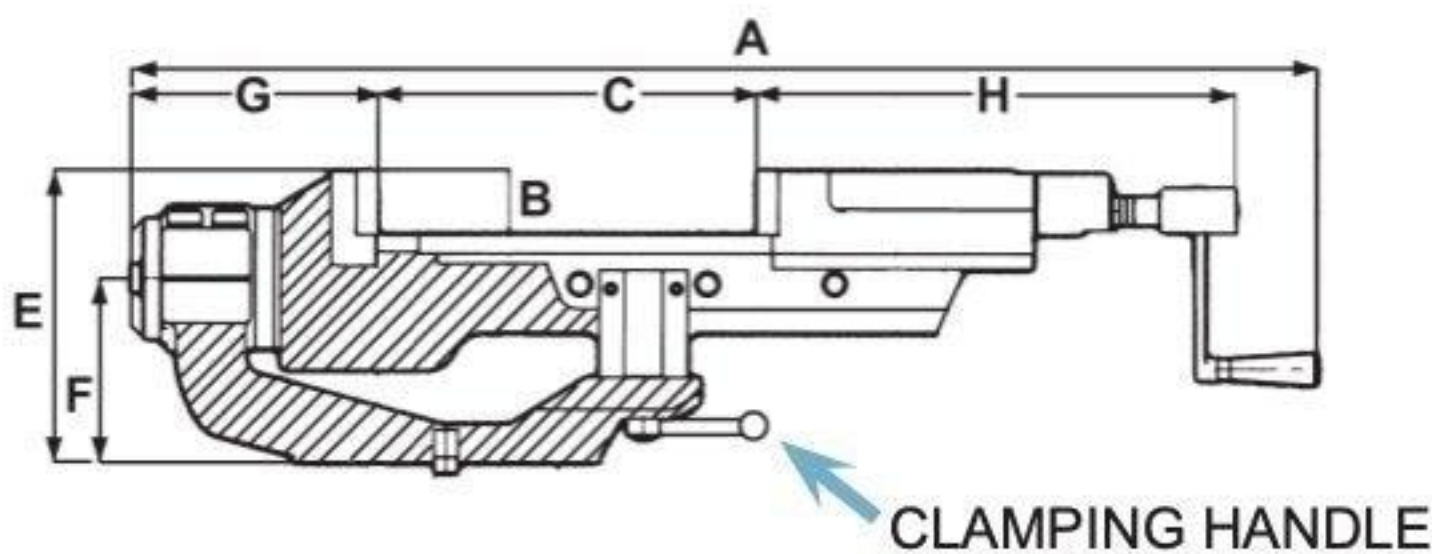
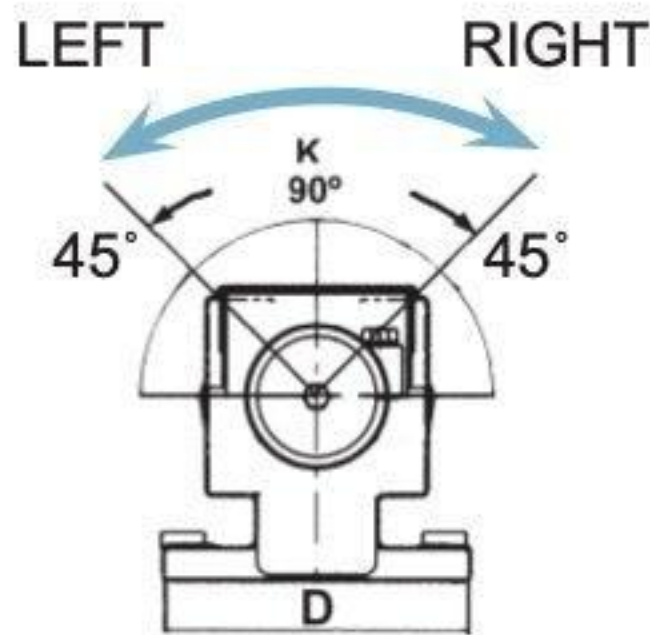

- New design: adjustable pressure device.
- Suit for processing of brass, AL, plastic, steel.
- New design: super open jaw size, smallest open jaw size.
- Lock proof system: prevent wrong clamping force sticks the vise.
- 45 Degree tilting function by hand, allow 90 degree processing!
- Tilting function has more work free allowance will not block or hit machine!
- Lower overall height provides more space for heavy cutting stability and bigger workpiece!
- Tilting structure has strong tightening design.
- All function same as VH series. Except the tilting Structure.

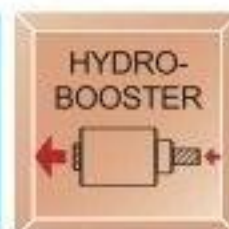
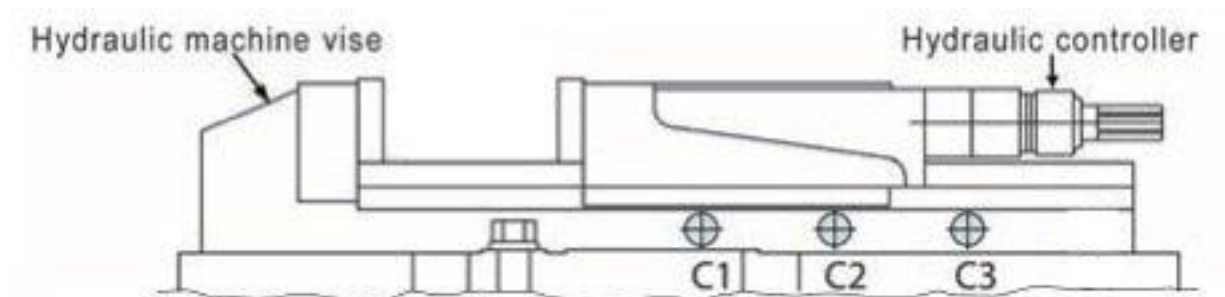

ORDER NO.	A	B	C OPEN	Opening Size For Capacity			D	E	F	G	H	Max. Clamp Force (kgf)	K Max. Degree	G.W. (kgs)	CODE NO.
				C1	C2	C3									
VHT-4U	690	36	170	0-58	56-115	113-170	ø165	175	110	130	290	2500	90°	37.39	1002-025
VHT-6U	940	54	300	0-100	98-200	198-300	ø225	235	140	150	375	4500	90°	93.96	1002-026