

Ref. 32030

STRAIGHT RADIUS



P				M		K			N				S		H		
>800	>1.000	>1.200	>1.400	>950	>1.200	>500	>800	>1.400	Al	Cu	Mg/Zn	Plastic	Ti	Ni	50 HRC	55 HRC	60 HRC

Vc (m/mm) ● Best ○ Alternative

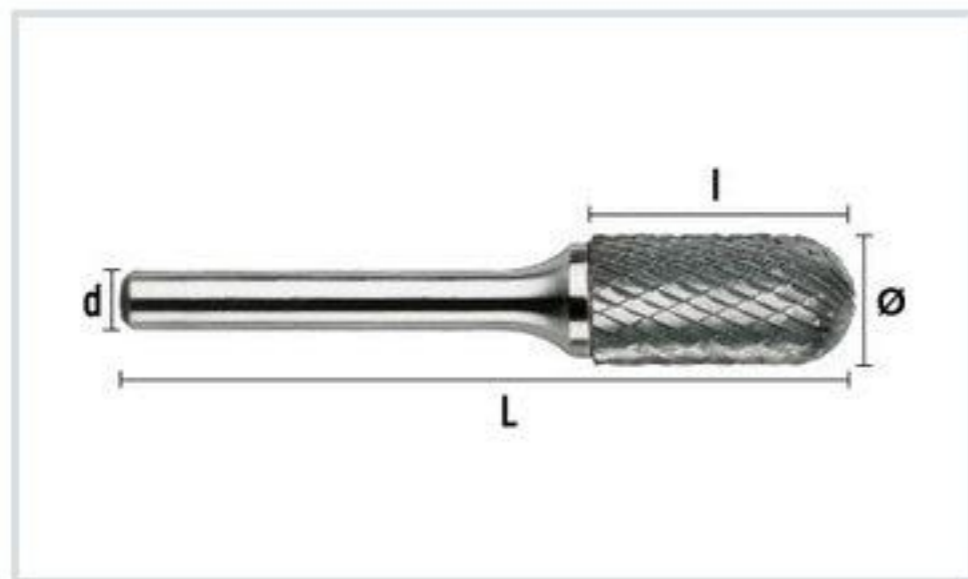

Características técnicas:

- › Carbide HM
- › Straight radius shape
- › CROSS toot

Aplicaciones:

Soft magnetic steels, construction and cementation steels, and non-alloy and alloy carbon steels up to a strength of 1,100 N / mm²