

HP-50Z

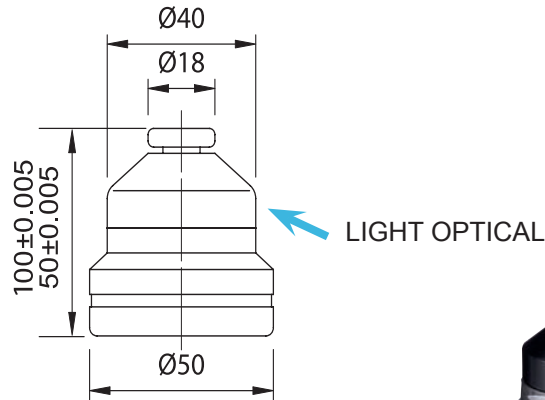

HP-50Z BATTERY
LR4476AG13
1SET/2PCS
HP-50ZM
LR44
1SET/2PCS

MODEL For NEXT

- Height 50 mm and 100 mm.
- With Magnetic base.
- The red lamp will be lighted up when touched.
- Accuracy 0.005 mm.
- Combined vertical and horizontal in a unit.
- Weight:0.7 kgs



HP-100ZM

HP-100Z

HEIGHT PRESETTER

- A. HP-50 / 100 / ZM / EM SERIES BUILT-IN MEGNETS FOR EASIER SETUP. VERTICAL & HORIZONTAL !
- B. STANDARD HEIGHT : 50 OR 100 MM
- C. WEIGHT ABOUT 0.7-1.2 KGS
- D. WHEN TOUCHED, THE RED LAMP LIGHTS ON.
- E. ACCURACY : WITHIN 0.005 MM
- F. BATTERY TYPE : LR44 / A76 / G13 X 2 PCS

MANUAL:

1. THERE IS A MECHNISM BELOW THE TOUCH PLATE CAN BE ADJUSTED BY GAUGE BLOCK.
 2. WHEN MACHINE SPEED IS HIGH, PLEASE REDUCE THE SPEED & GO UP /DOWNWARD UNTIL THE RED LIGHT IS OFF.
 3. PROCEED AGAIN IN LOWER SPEED.
 4. HORIZONTAL POSITION (HPXXX-XXEM/ZM SERIES-MAGNETIC FUNC.ONLY)
PLEASE USE THE TOP TIP OF THE CUTTER TO TOUCH THE TOUCH PLATE.
- ※ CAN NOT USE VERNIER TO CHECK / RE-SET

EXAMPLE

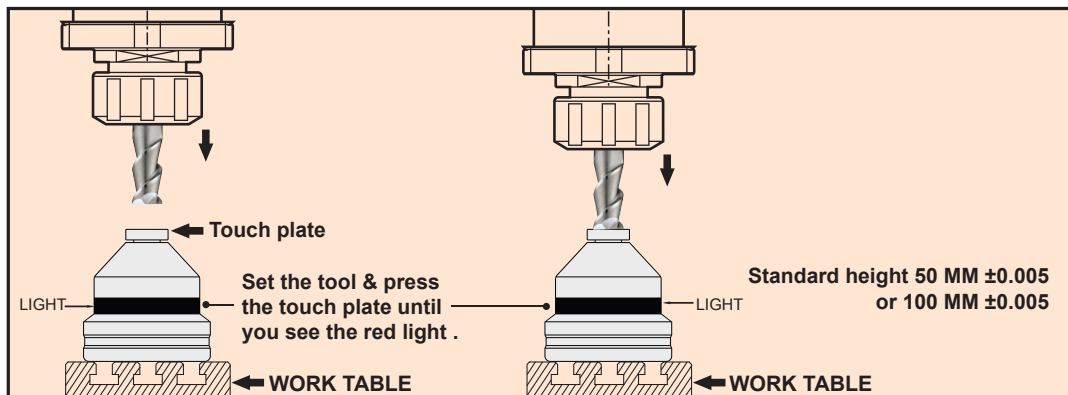

ORDER NO.	H	STYLE	WEIGHT (kg)		CODE NO.
			N.W.	G.W.	
HP-50Z	50mm	STANDARD TYPE	0.32	0.7	3403-001
HP-50ZM	50mm	WITH MAGNETIC BASE	0.32	0.7	3403-002
HP-100Z	100mm	STANDARD TYPE	1.0	1.25	3403-003
HP-100ZM	100mm	WITH MAGNETIC BASE	1.0	1.22	3403-004

NEW