

# LARGE RANGE DIAL TEST INDICATOR

JEWELLED  
BEARING

**INSPECTION  
CERTIFICATE**  
TRACEABLE TO NIST

- Dial reading: 0-40-0
- Jeweled bearing
- Carbide contact point
- Two measuring directions
- Anti magnetic body
- Supplied with two clamps:  
diameter  $\varnothing 4\text{mm}$  and  $\varnothing 8\text{mm}$
- Optional accessory: styli (page 182)



2386-16A

clamp (included)

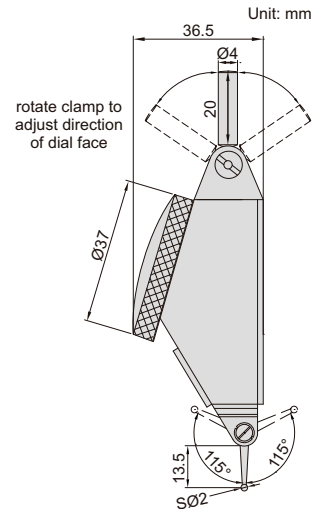
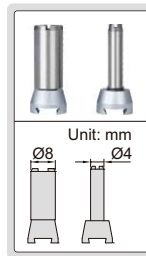

Code	Range	Graduation	Accuracy	Hysteresis
2386-16A*	1.6mm	0.01mm	25 $\mu\text{m}$	8 $\mu\text{m}$

\*Supplied with manufacturer inspection certificate traceable to NIST USA