

# HORIZONTAL & VERTICAL TWO DIRECTION

# RAPID INDEXER



Useful for 2 Direction horizontal & Vertical milling and drilling operations. It has a 3 Jaw chuck fitted on the head for big range clamping. The indexer has a simple rapid operation with Dividual number 24 - notch (15° each) and a Table scale of 1° for angular indexing.

1. 3 Jaw chuck fitted Head with big range clamping capacity.
2. Dividual number 24-notch (15° each)
3. Table scale 1°, for angular indexing
4. Horizontal / Vertical & 2 direction
5. Suit for milling & drilling machine

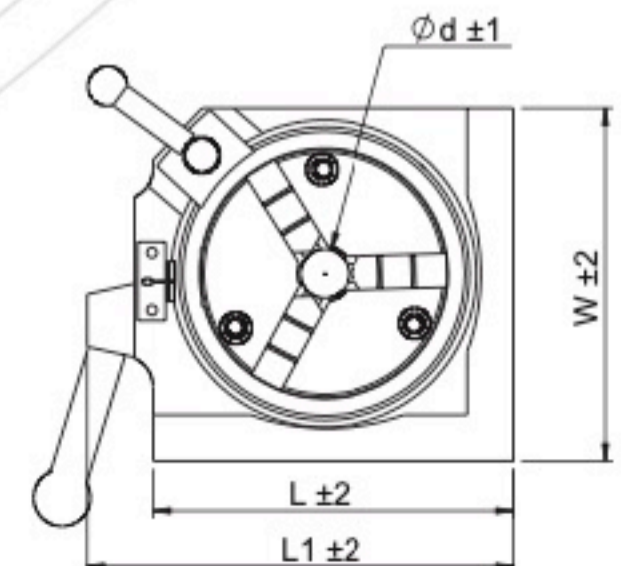
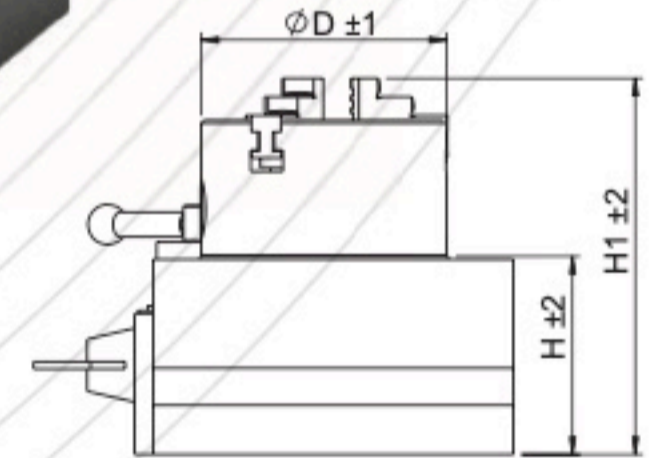
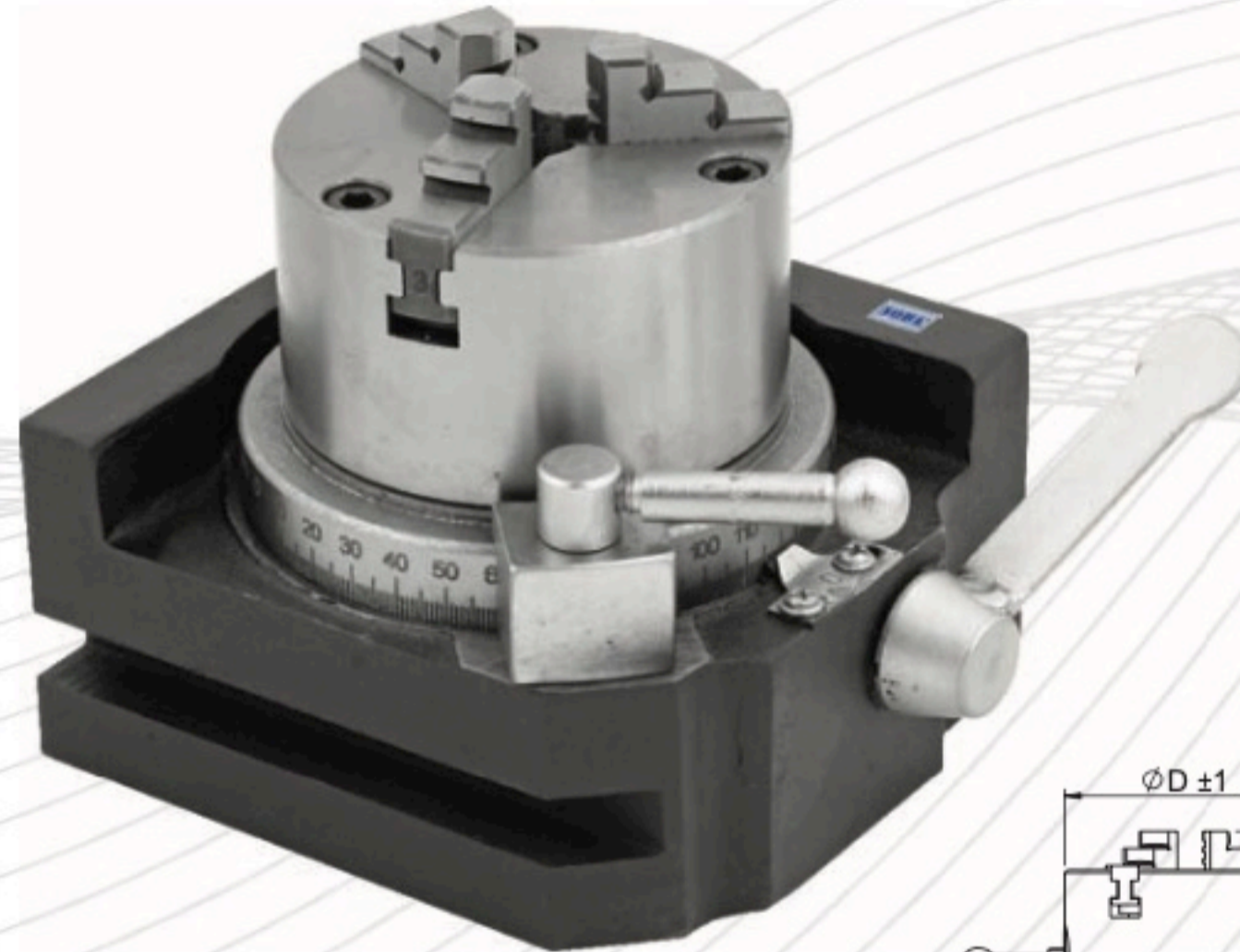
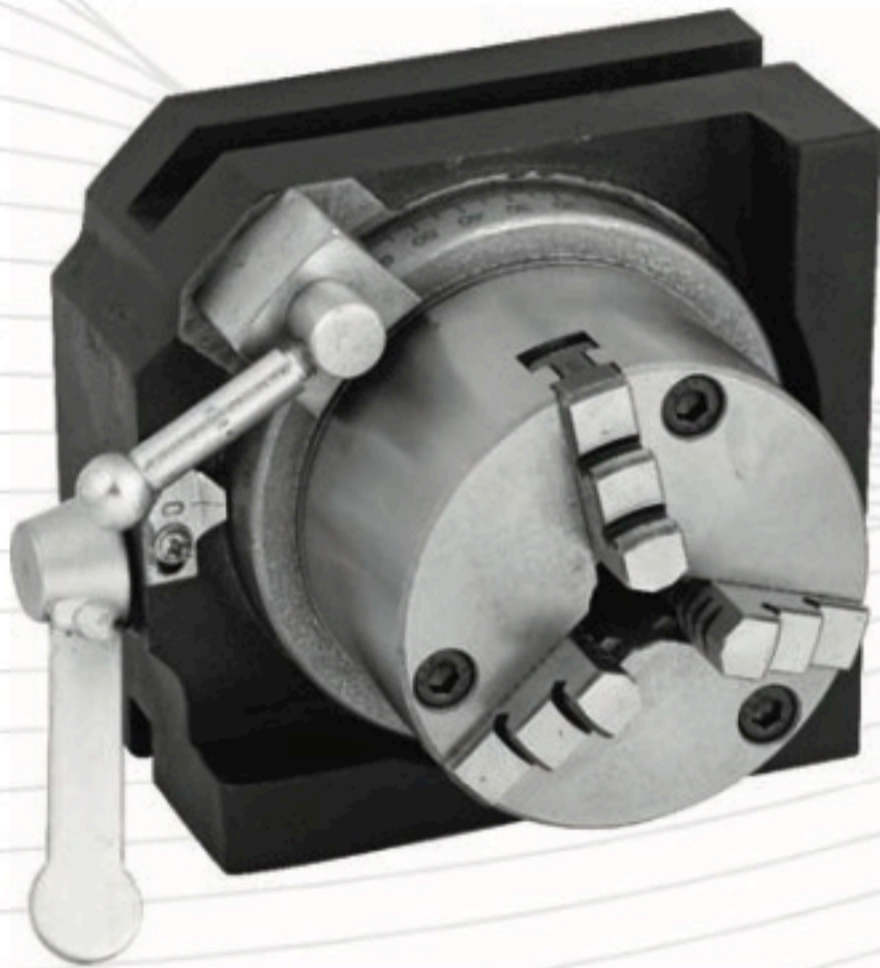

## TECHNICAL DATA

Ordering No.	Chuck Dia ( $\phi D$ )		Over Length (L1)		Length (L)		Width (W)		Height (H)		Centre Bore ( $\phi d$ )		Over Height (H1)		Clamping Capacity (Min~Max)	Net Weight
	Inch	mm	Inch	mm	Inch	mm	Inch	mm	Inch	mm	Inch	mm	Inch	mm		
110275	3.1/8	80	5.3/8	137	4.9/16	115	4.9/16	115	2.9/16	65	5/8	16	4.3/4	121	3~76	6.0
110280	4	100	6.1/2	165	5.1/2	140	5.1/2	140	2.9/16	65	3/4	19	5.3/8	137	3~100	9.35
110285	5	125	7.5/8	194	6.1/2	165	6.1/2	165	2.9/16	65	1	25	6.1/8	155	3~125	14.35