

OUTSIDE DIAMETER VARIATION MEASURING INSTRUMENTS

CAN BE CUSTOM-MADE

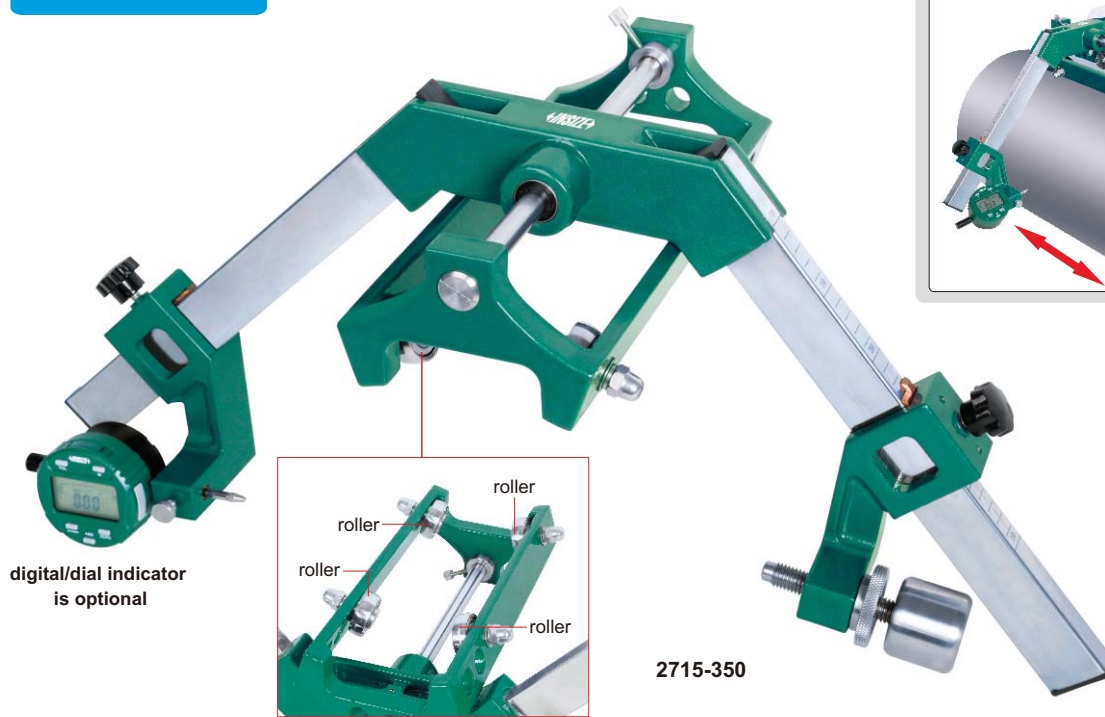

application

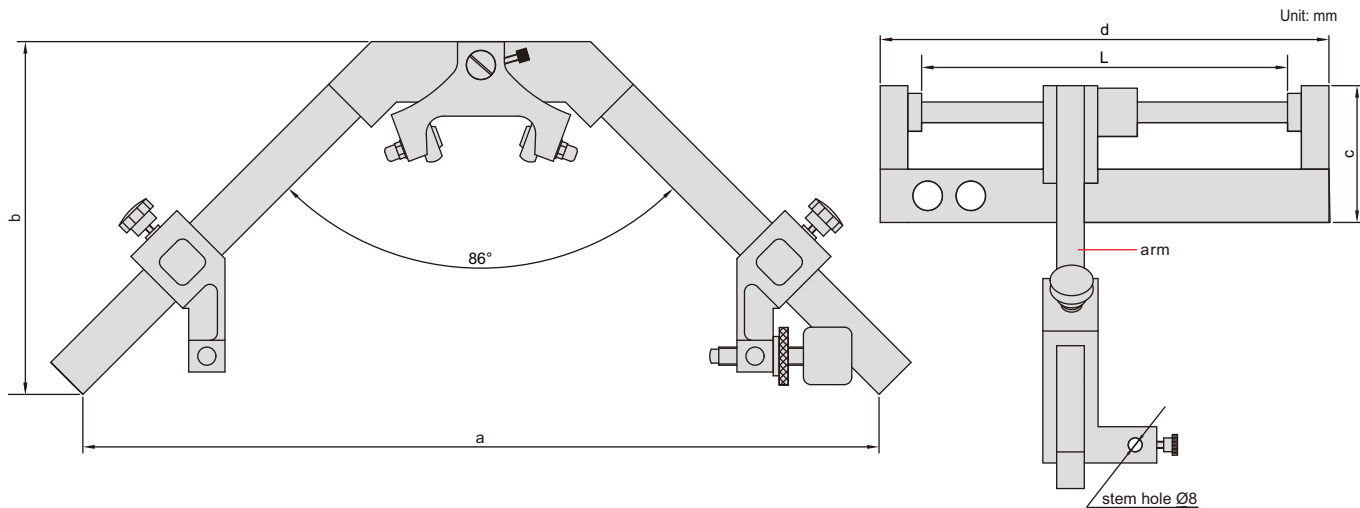

- Measurement of diameter variation, convexity, concavity, taper and other parameters
- Continuous measurement in the axis direction
- Four rollers are included
- Optional accessory: 0.01mm or 0.001mm graduation digital/dial indicators

(mm)

Code	Range	Accuracy	Repeatability	Arm moving range(L)	a	b	c	d
2715-350	100-350mm/4-14"	0.01mm	3µm	200mm	500	230	80	260
2715-500	200-500mm/8-20"	0.01mm	3µm	151mm	630	260	95	260
2715-700	300-700mm/12-28"	0.01mm	3µm	197mm	910	372	112	320
2715-1000	500-1000mm/20-40"	0.01mm	3µm	190mm	1170	460	120	320
2715-1600	800-1600mm/32-64"	0.02mm	6µm	202mm	1860	690	180	320
2715-2000	1400-2000mm/56-80"	0.02mm	6µm	232mm	2156	860	210	350