

# Slim - profiled, extended centre point

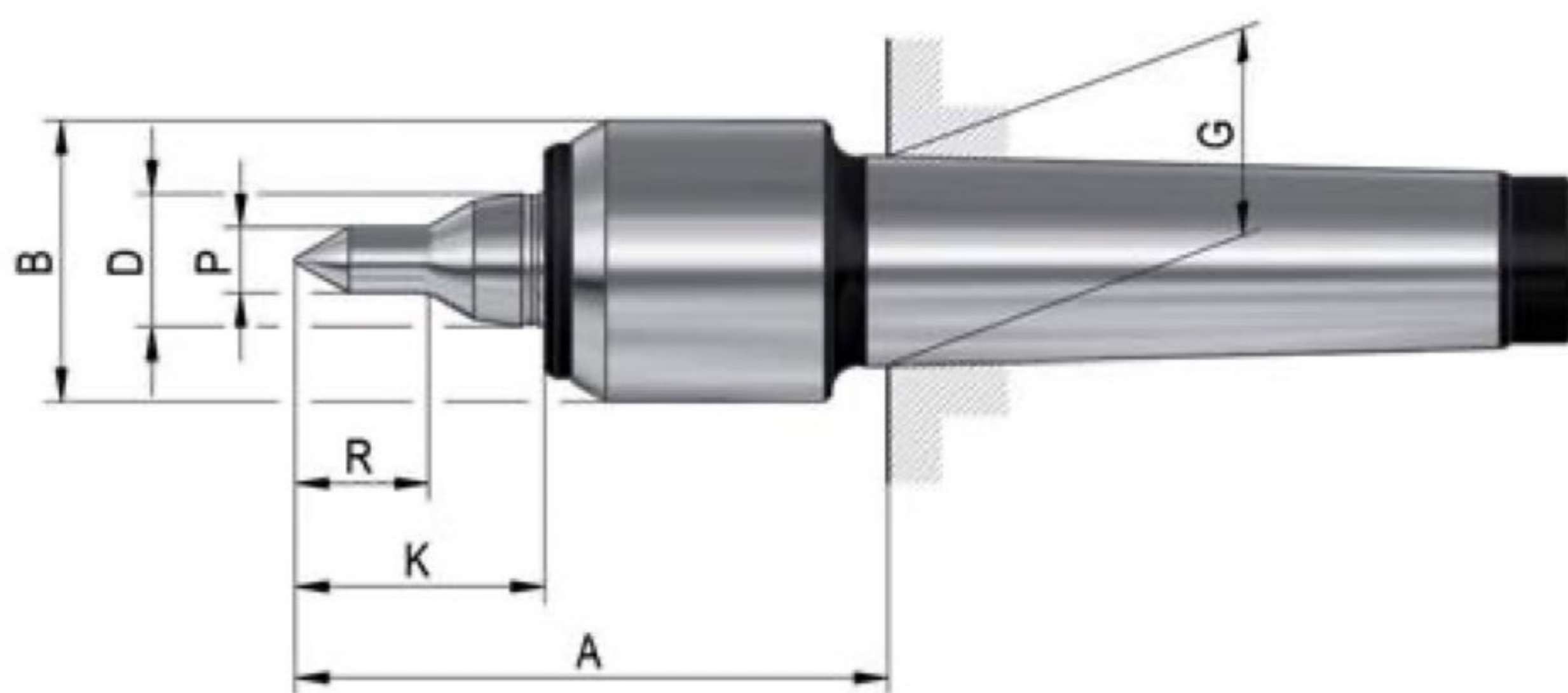

## APPLICATION

For counter-clamping workpieces on turning and grinding machines. Especially suited for cramped work area between centre point and workpiece.

## TYPE

Compact design with minimum casing diameter. With extended and profiled centre point.

## CUSTOMER BENEFITS

- ⊕ Enlarged work area and better workpiece accessibility thanks to narrow casing diameter and extended and profiled centre point
- ⊕ Maximum rigidity at high speeds thanks to compact design
- ⊕ Maximum concentricity deviation of 0.008 mm for maximum precision

## TECHNICAL FEATURES

- Body hardened and ground
- Tip angle 60°

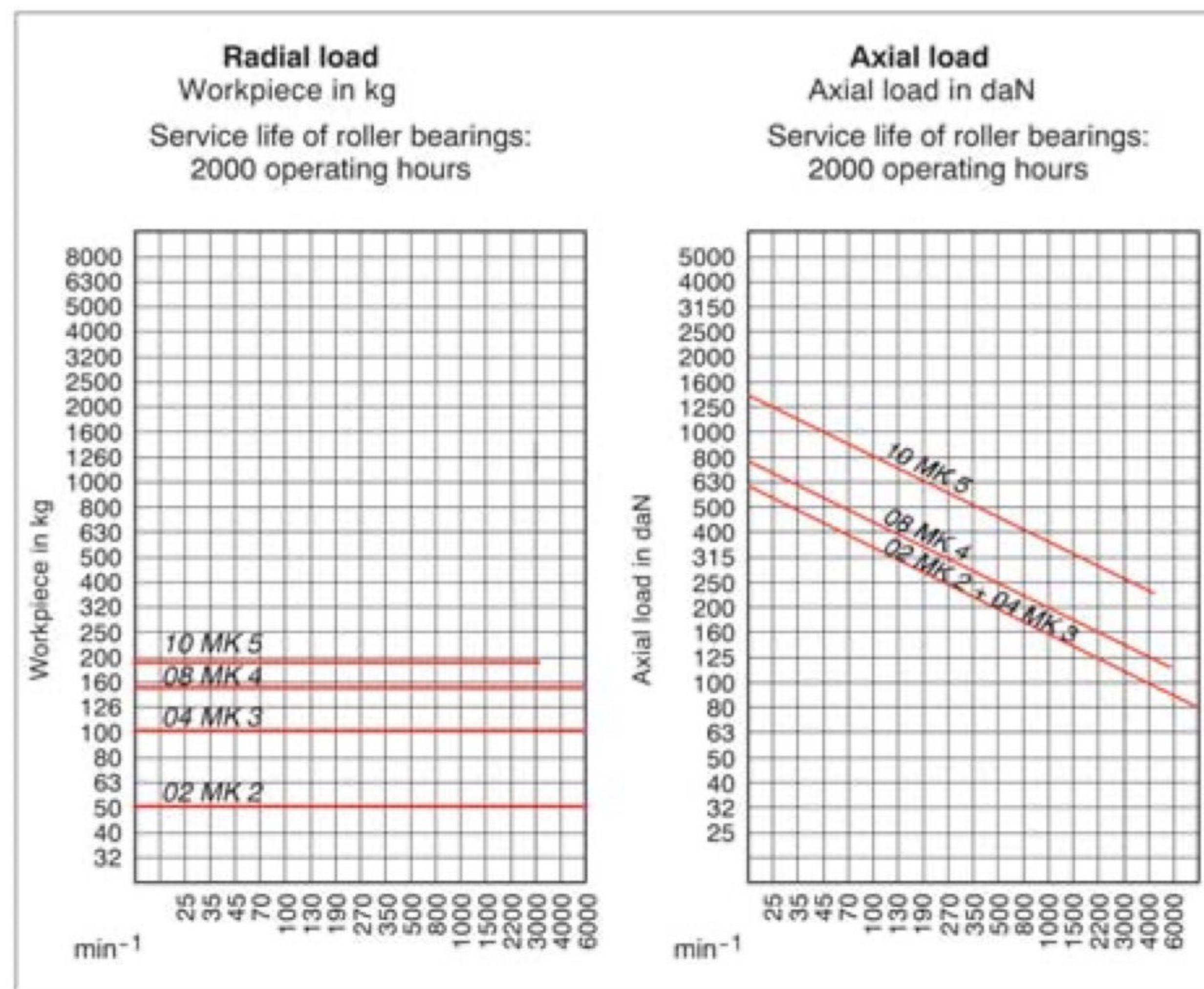

A06  
Slim **with small casing diameter** and **profiled and extended centre point**, body hardened and ground - tip angle 60°

Item no.	1241695	1243505	1243507	1243509
Mount MT	2	3	4	5
Size	02	04	08	10
A mm	73	74	88,5	119
B mm	32	34	42	58
D mm	15	15	20	30
G mm	17,78	23,825	31,267	44,399
K mm	29,5	32	37,5	51,5
P mm	6	8	10	12
R mm	12	16	20	26
Workpiece weight max. kg	50	100	150	180
Concentricity deviation max. mm	0,008	0,008	0,008	0,01
Speed max. min <sup>-1</sup>	7000	7000	6300	4300
Weight approx. g	320	460	1000	2600
<b>Spare live centres</b>	<b>1241758</b>	<b>1241759</b>	<b>1241760</b>	<b>1241761</b>