

**IP65**  
WATERPROOF

- Dust/waterproof level: IP65
- LED display, remote control
- Low voltage indicator
- Unit: kg, lb
- Automatic power off
- Overload alarm
- 360° safe rotary hook and shackle
- Aluminum alloy die casting case with high strength

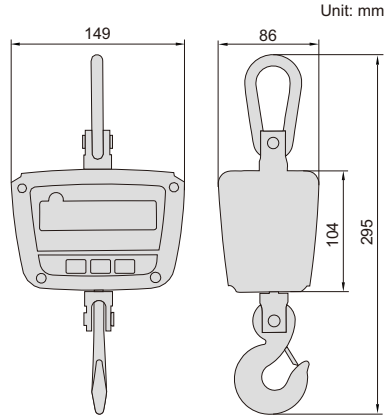

### SPECIFICATION

| Code                      | 8201-50KG  | 8201-150KG    | 8201-300KG    |
|---------------------------|--|---------------|---------------|
| Maximum weighing          | 50kg   | 150kg         | 300kg         |
| Minimum weighing          | 0.4kg  | 1.0kg         | 2.0kg         |
| Resolution (d)            | 0.02kg/0.01kg                                      | 0.05kg/0.02kg | 0.10kg/0.05kg |
| Verification interval (e) | 0.02kg   | 0.05kg        | 0.10kg        |
| Accuracy                  | ±0.02kg  | ±0.05kg       | ±0.10kg       |
| Operation temperature     | -10~40°C   |               |               |
| Operation humidity        | 30%~90% RH   |               |               |
| Overload alarm            | 100%F.S.+9e  |               |               |
| Maximum safe load         | 125%F.S.   |               |               |
| Limited overload          | 400%F.S.   |               |               |
| Power supply              | rechargeable battery 6V/3Ah (for 40 hours working) |               |               |
| Stable reading time       | ≤8s  |               |               |

## ELECTRONIC CRANE SCALES



Remote controller  
(included)

8201-150KG

### STANDARD DELIVERY

|                   |      |
|-------------------|------|
| Main unit         | 1 pc |
| Remote controller | 1 pc |
| Battery charger   | 1 pc |