

All knurls are produced from M2 (High Speed Steel) and hardened to 62 HRC. All knurls are tested to assure work of uniform precision. Manufacturing tolerances are highly precise for knurl thickness and hole diameter. The hole is always concentric and the patterns on the knurls are created under rolled cut method. We offer knurls of straight pattern, Left hand spiral, Right hand spiral and Cross knurl.

Spare Knurls Knurls with straight pattern, Left hand spiral, Right Hand Spiral, Cross Knurl Points up 30°, 45°. Cross Knurl down 30° or 45°. We offer in Extra fine, medium and Coarse Pitcher

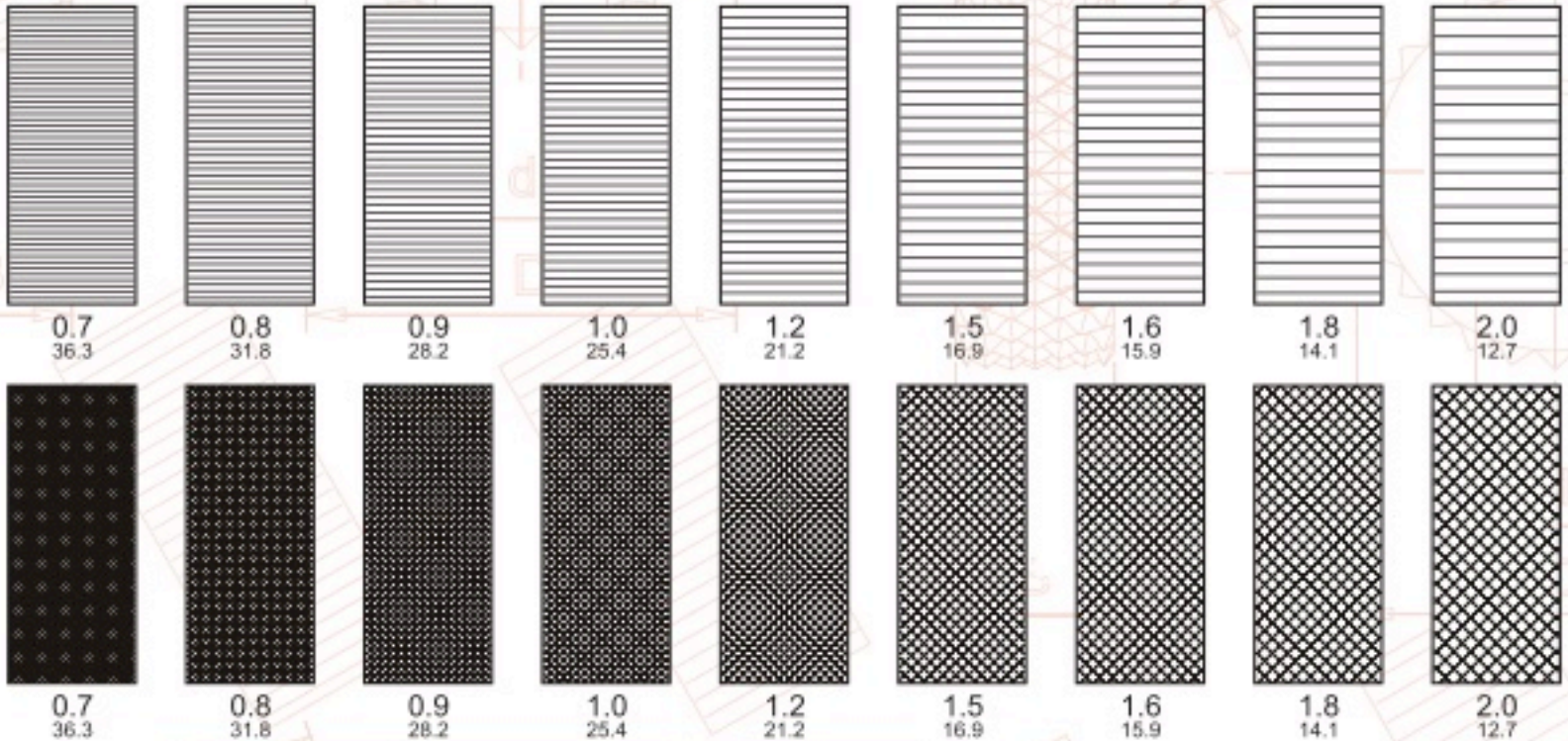
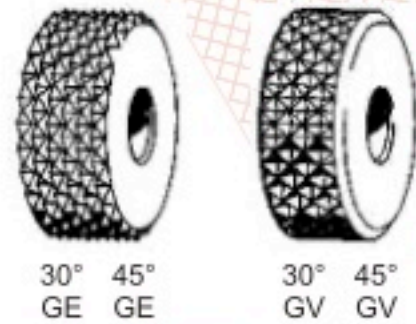
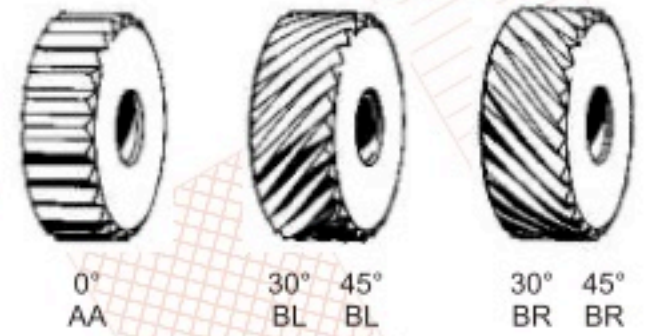
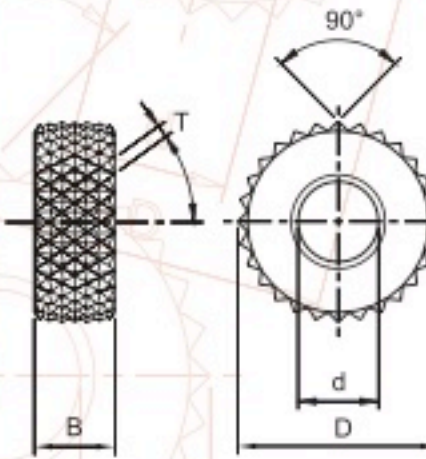
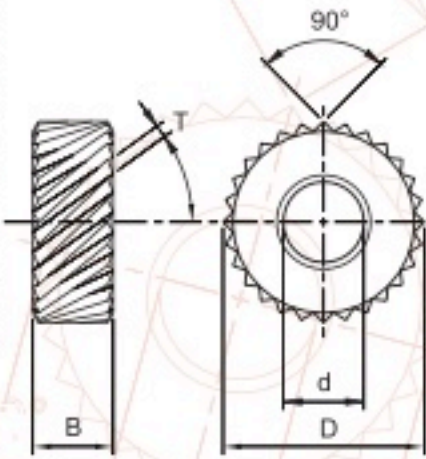

DIA		WIDTH		BORE	
Inch	mm	Inch	mm	Inch	mm
3/4	19	1/4	6.35	1/4	6.35
3/4	19	3/8	9.5	1/4	6.35
1	25.4	3/8	9.53	1/4	6.35
5/8	16	5/16	7.9	7/32	5.5
5/8	16	3/16	5	7/32	5.5
1/2	12.7	1/4	6.35	3/16	4.95
	20		8		6
	15		6		4
	15		4		4

- AA - Straight
- BL - Left Hand Spiral. 30°, 45°
- BR - Right Hand Spiral. 30°, 45°
- GE - Cross - Knurl Points Up 30°, 45°
- GV - Cross - Knurl Points Down 30°, 45°