

Crankshaft Deflection Gauge

- Exclusive instrument to measure deflections of engine crank of automobiles and ships etc.
- This is analog type and can be used without battery, and 3 kinds of extension rods are provided as standard accessory.

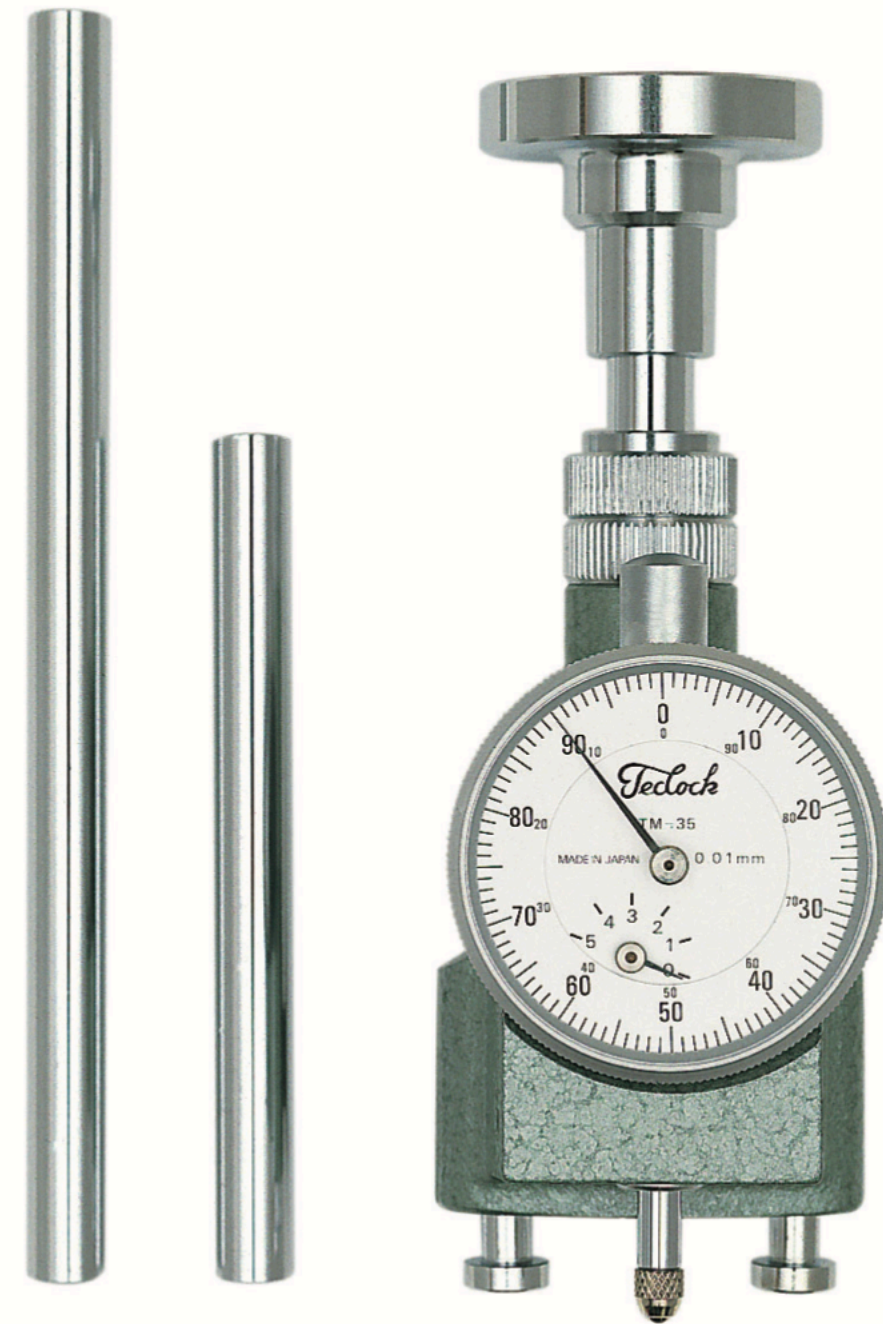

CSDG-A
 Graduation 0.01mm
 Measuring Range 110~230mm

Dimension Table (extension rods)

NO.	L	Measuring Range
1	40	110~150mm
2	80	150~190mm
3	120	190~230mm

unit : mm

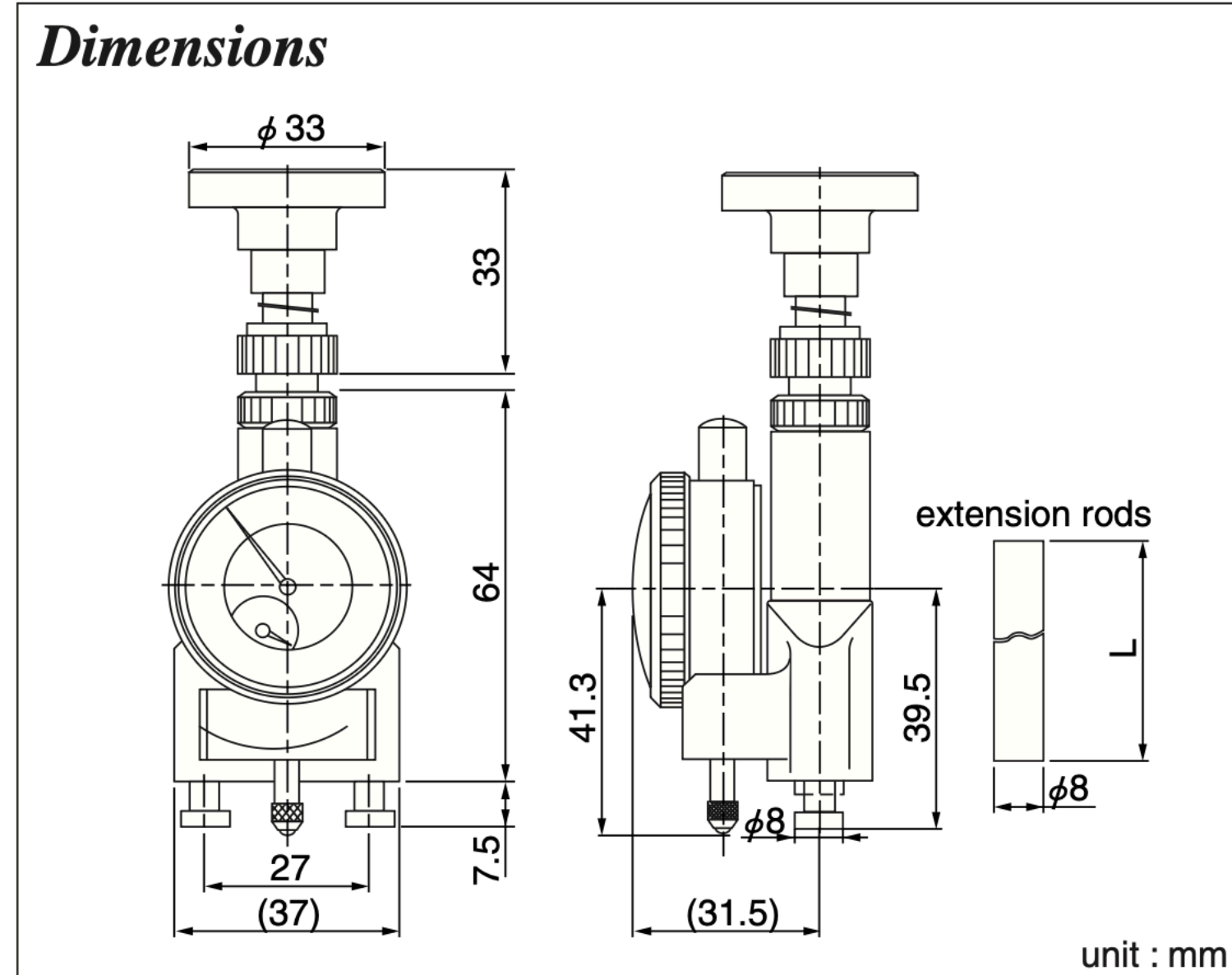

Specifications

Model	Graduation	Measuring Range (mm)	Indication Error (μm)	Weight (g)
CSDG-A	0.01	110~230	± 15	300