



Keyless Drill Chucks



TYPE: XHSP

SPECIAL HEAVY DUTY TYPE

FOR DRILL ONLY , NOT FOR END MILL OR TAP



OPTIONAL ACCES.

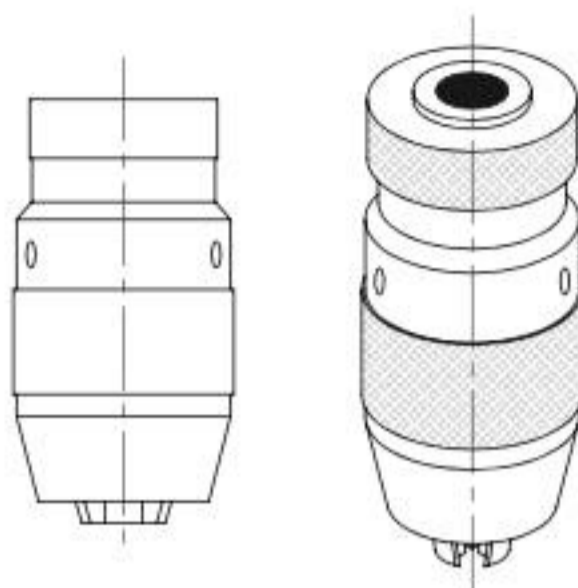

- Special design & manufacture against for super heavy torque(Clamping capacity) use.
- Owing to inspecting strictly & with excellent RUNOUT Accuracy and quality guanteed the gripping power is double than the general brand.
- Avoid the drill dropped when used in instaneous change of direction and equipped with spanner hole for tightening perfect safety.
- Especially suitable for CNC machining center & milling machine use.
- Accuracy: 50 mm length within 0.05 mm
- The key is optional

Unit:mm

ORDER NO.	TYPE	Clamping Capacity		Female Taper DIN or Jacobs	OUTER Ø / mm	Length		Wt g	QTY Pcs./ Cu-Ft	N.W/G.W kgs	CODE NO.
		Ø mm	Ø inch			Open B mm	Closed A mm				
11015	8XHSP	0.5-8	0-5 / 16"	B10	34.3	64.8	72.7	320	40/0.6	13/14	3302-002
11016				J1	34.3	64.8	72.7	320	40/0.6	13/14	3302-003
11017				B12	34.3	64.8	72.7	320	40/0.6	13/14	3302-004
11018	10XHSP	1-10	0-3 / 8"	J33	42.4	80.8	91.1	700	40/0.6	28/29	3302-005
11019				J2S	42.4	80.8	91.1	700	40/0.6	28/29	3302-006
11020				B12	42.4	80.8	91.1	700	40/0.6	28/29	3302-007
11021				B16	42.4	80.8	91.1	700	40/0.6	28/29	3302-008
11025	13XHSP	1-13	0-1 / 2"	J6	50.3	93.7	105.3	1030	30/0.6	31/32	3302-009
11026				J33	50.3	93.7	105.3	1035	30/0.6	31/32	3302-010
11027				B16	50.3	93.7	105.3	1030	30/0.6	31/32	3302-011
11028	16XHSP	3-16	1/8 - 5/8"	J6	52	97	110.3	1450	24/0.6	35/36	3302-012
11029				B16	52	96.1	110.3	1450	24/0.6	35/36	3302-013
11030				B18	52	97	110.4	1450	24/0.6	35/36	3302-014
11035				J3	52	100.5	105.3	1450	24/0.6	35/36	3302-015
17000	6XHSP	0.5-6.5	1/64"- 1/4"	B12	34	64.8	72.7	320	40/0.6	13/14	3304-010
17002				J1	34	64.8	72.7	320	40/0.6	13/14	3304-011
17004				B10	34	64.8	72.7	320	40/0.6	13/14	3304-012
11031	Key	13XHSP		OPTIONAL ACCES.							3304-001
11032		16XHSP									3304-002
11033		8XHSP									3304-003
11034		10XHSP									3304-004

