

ARROW WELDING MAGNET

FM1 箭头形焊接固定器

Application: Can be used for welding, soldering, pipe installation, assembly, magnetic pick-up tool etc.

Features: 1. Strong ferrite magnet encased in durable steel casing and reinforced with rivets.
2. Multi-angle design can be used at 45, 90 or 135 degrees.

用途: 可用于焊接、管道安装、装配、磁力拾取工具等

特点: 1. 铁氧体磁体, 吸力强劲。坚固耐用的钢制外壳, 用铆钉加固

2. 多角度设计, 可在45°, 90°, 135°使用

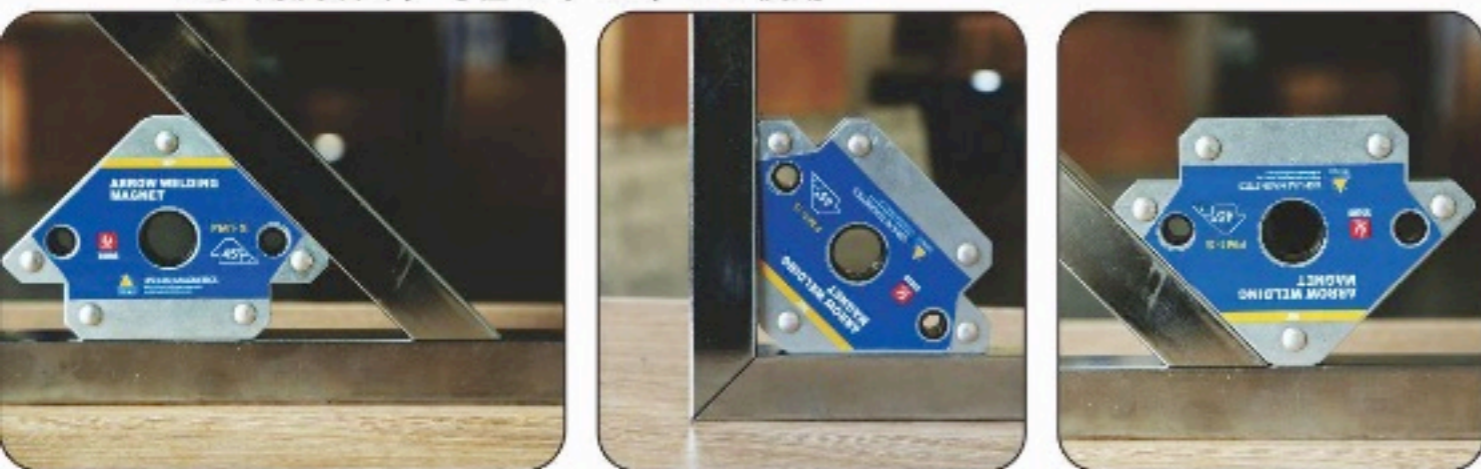

FM1-XS

FM1-S

FM1-M

FM1-L

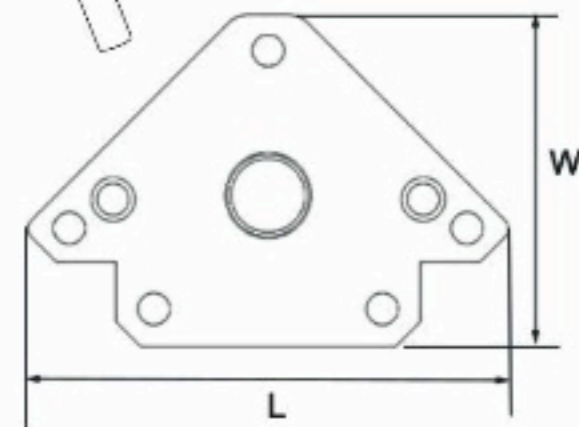
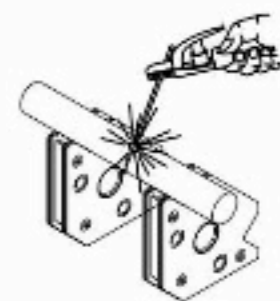

型号 Model	规格 Dimension (mm)			角度 Angles	净重 (kg) Net Weight	拉脱力 (kg) Pull Off Force	
	L	W	T				
FM1-XS	80	54	12	45°/90°/135°	0.12		12.5
FM1-S	121	83	18	45°/90°/135°	0.4		25
FM1-M	163	112	23	45°/90°/135°	0.85		50
FM1-L	198	136	27	45°/90°/135°	1.4		75