

7101

TCT Metal Duro
Métal Dur / Hard Metal

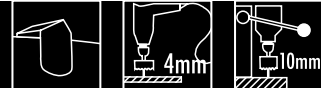

P				M		K			N				S		H		
<800	<1.000	<1.200	<1.400	<950	<1.200	<500	<800	<1.400	Al	Cu	Mg/Zn	Plastic	Ni	Ti	50 HRC	55 HRC	60 HRC
o	o	o		•	•				o			o					

Vc (m/min). ● Optima / Optimun ○ Alternativo / Alternative

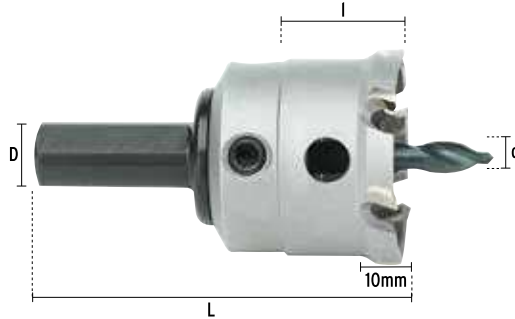

Ø mm	L mm	l mm	z	d mm	D mm	
18,00	67,50	22	4	6	10	1
19,00	67,50	22	4	6	10	1
20,00	67,50	22	4	6	10	1
21,00	67,50	22	4	6	10	1
22,00	67,50	22	4	6	10	1
23,00	67,50	22	4	6	10	1
24,00	67,50	22	4	6	10	1
25,00	67,50	22	4	6	10	1
26,00	67,50	22	6	6	10	1
27,00	67,50	22	6	6	10	1
28,00	67,50	22	6	6	10	1
29,00	67,50	22	6	6	10	1
30,00	67,50	22	6	6	10	1
31,00	67,50	22	6	6	10	1
32,00	67,50	22	6	6	10	1
33,00	67,50	22	6	6	10	1
34,00	67,50	22	6	6	10	1
35,00	67,50	22	6	6	10	1
36,00	67,50	22	6	6	10	1
38,00	67,50	22	6	6	13	1
39,00	67,50	22	6	6	13	1
40,00	67,50	22	6	6	13	1
41,00	67,50	22	6	6	13	1
42,00	67,50	22	6	6	13	1
43,00	67,50	22	6	6	13	1
44,00	67,50	22	6	6	13	1
45,00	67,50	22	6	6	13	1
46,00	67,50	22	6	6	13	1
48,00	67,50	22	6	6	13	1
49,00	67,50	22	6	6	13	1
50,00	67,50	22	6	6	13	1
51,00	67,50	22	6	6	13	1
52,00	67,50	22	6	6	13	1
53,00	67,50	22	6	6	13	1
55,00	67,50	22	6	6	13	1
56,00	67,50	22	6	6	13	1
57,00	67,50	22	6	6	13	1
58,00	67,50	22	6	6	13	1
59,00	67,50	22	6	6	13	1

7101

TCT Metal Duro
Métal Dur / Hard Metal



P				M		K			N				S		H		
<800	<1.000	<1.200	<1.400	<950	<1.200	<500	<800	<1.400	Al	Cu	Mg/Zn	Plastic	Ni	Ti	50 HRC	55 HRC	60 HRC
o	o	o		•	•				o			o					

Vc (m/min). ● Optima / Optimun ○ Alternativo / Alternative

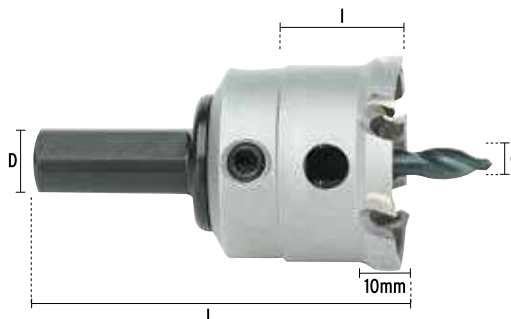

Ø mm	L mm	l mm	z	d mm	D mm	
60,00	67,50	22	6	8	13	1
61,00	67,50	22	8	8	13	1
62,00	67,50	22	8	8	13	1
63,00	67,50	22	8	8	13	1
64,00	67,50	22	8	8	13	1
65,00	67,50	22	8	8	13	1
66,00	67,50	22	8	8	13	1
67,00	67,50	22	8	8	13	1
68,00	67,50	22	8	8	13	1
69,00	67,50	22	8	8	13	1
70,00	67,50	22	8	8	13	1
75,00	67,50	22	10	8	13	1
80,00	67,50	22	10	8	13	1
85,00	67,50	22	10	8	13	1
90,00	67,50	22	12	8	13	1
95,00	67,50	22	12	8	13	1
100,00	67,50	22	12	8	13	1

Accesorios / Accessoires / Accessories

► Ref. 7102 Broca de Centrar / Centre drill-bit / Foret de centrage



Ø mm	Hex.	L mm	
18,00 - 60,00	6	50	1
61,00 - 100,00	8	50	1

► Ref. 7103 Cono morse / Cône morse / Morse taper



Ø mm	Hex.	L mm	
61,00 - 100,00	-	-	1