



MORSE TAPER ARBOR

MTA

MORSE TAPER ARBOR

EINSATZHÜLSEN FÜR MORSEKEGEL
DOUILLES DE RÉDUCTION CÔNE MORSE
MANDRINO RIDUZIONE CONO MORSE
REDUCTORES A MORSE

ANSI B5.18-NT

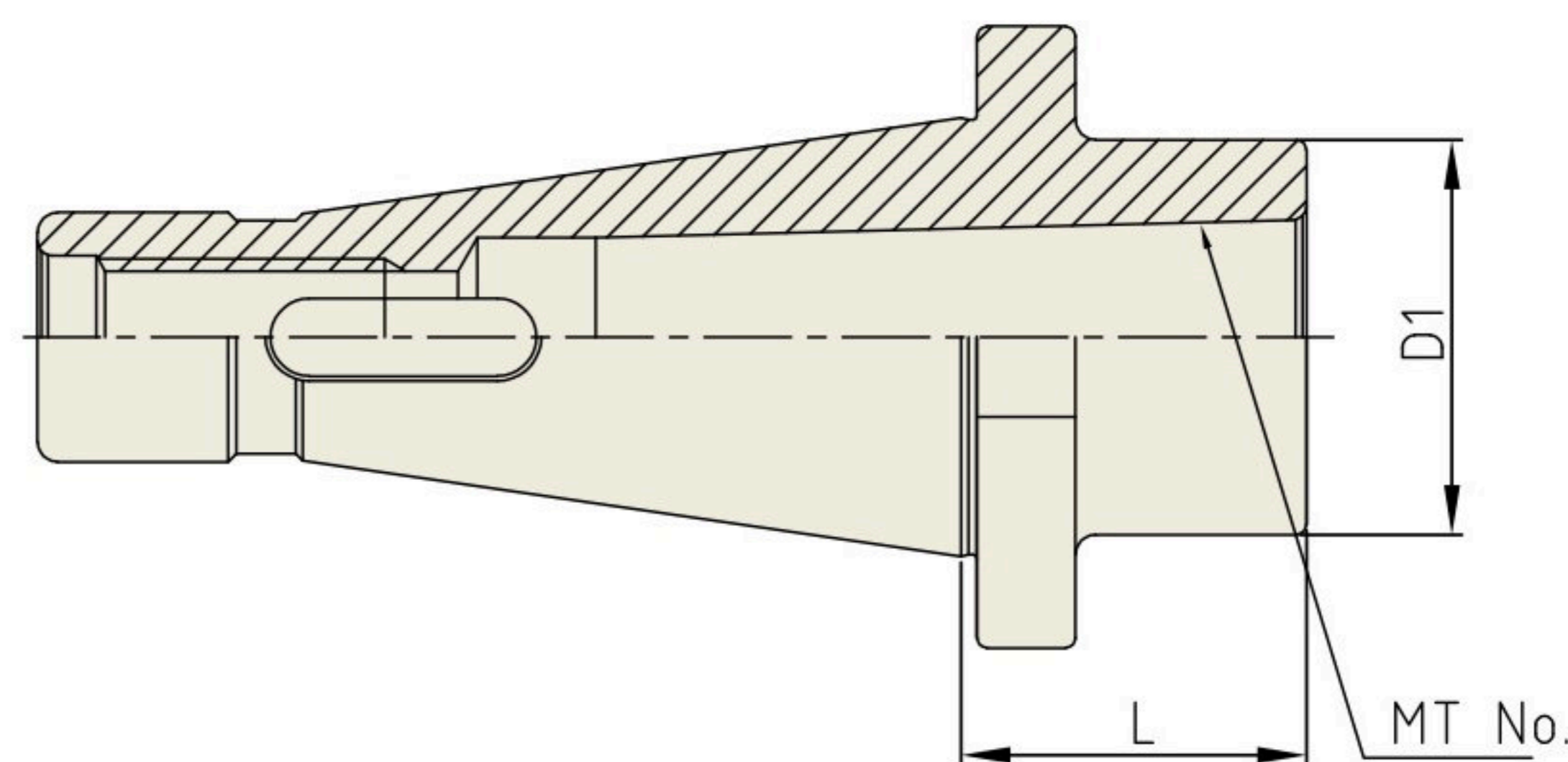

ANSI
B5.18 -
NT



Unit : mm

TAPER No.	MODEL No.	EDP No.	MT No.	RANGE OF DRILL		D1	L	DRAW THREAD	WEIGHT (Kg)
				Min.	Max.				
40	NT40-MTA1-30	P2542051	1	2.0	14.0	25	30	U5/8-11(M16x2)	0.90
	NT40-MTA2-30	P2542052	2	14.1	23.0	32	30	U5/8-11(M16x2)	1.00
	NT40-MTA3-35	P2542053	3	23.1	32.0	40	35	U5/8-11(M16x2)	1.00
	NT40-MTA4-90	P2542054	4	32.1	50.0	50	90	U5/8-11(M16x2)	1.20
50	NT50-MTA1-30	P2542055	1	2.0	14.0	25	30	U1-8(M24x3)	3.50
	NT50-MTA2-30	P2542056	2	14.1	23.0	32	30	U1-8(M24x3)	3.50
	NT50-MTA3-30	P2542057	3	23.1	32.0	40	30	U1-8(M24x3)	3.50
	NT50-MTA4-45	P2542058	4	32.1	50.0	50	45	U1-8(M24x3)	3.50
	NT50-MTA5-105	P2542059	5	50.1	75.0	60	105	U1-8(M24x3)	4.00

► Inch type products are available.