

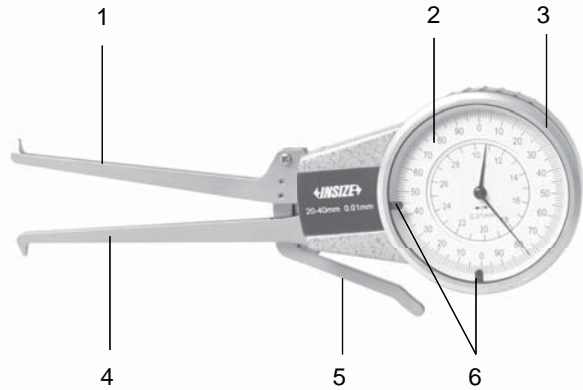

OPERATION INSTRUCTION

Internal/External Dial Caliper Gage

Series 2222/2333



Graduation: metric 0.01mm
inch 0.0005"

1. Movable caliper arm
2. Dial face
3. Bezel
4. Fixed caliper arm
5. Trigger
6. Tolerance index

Internal Dial Caliper Gage

Code	Range
2222-15	5-15mm
2222-20	10-20mm
2222-30	20-30mm
2222-40	30-40mm
2222-50	40-50mm
2222-25	5-25mm
2222-301	10-30mm
2222-401	20-40mm
2222-501	30-50mm
2222-60	40-60mm

2222-E06	0.2-0.6"
2222-E08	0.4-0.8"
2222-E12	0.8-1.2"
2222-E16	1.2-1.6"
2222-E20	1.6-2.0"
2222-E10	0.2-1.0"
2222-E121	0.4-1.2"
2222-E161	0.8-1.6"
2222-E201	1.2-2.0"
2222-E24	1.6-2.4"

It is necessary to set the original data before measuring. Find an outside micrometer and set it within the measuring range of the inside dial caliper gage. Clean the surface of micrometer tips and the measuring tips of gage. Sway the tips of the gage and find the minimum reading. Rotate the bezel of the gage to set the reading same as the micrometer. Measure the micrometer again and be sure the reading is the same as the micrometer.

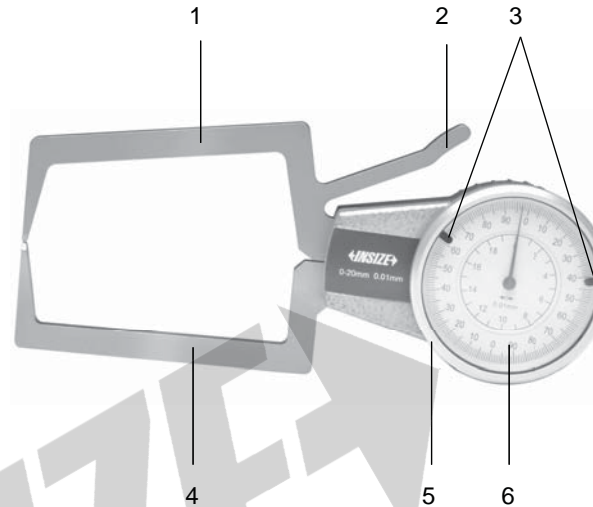

Graduation: metric 0.01mm
inch 0.0005"

1. Movable caliper arm
2. Trigger
3. Tolerance index
4. Fixed caliper arm
5. Bezel
6. Dial face

External Dial Caliper Gage

Code	Range
2333-10	0-10mm
2333-20	10-20mm
2333-30	20-30mm
2333-40	30-40mm
2333-50	40-50mm
2333-201	0-20mm
2333-301	10-30mm
2333-401	20-40mm
2333-501	30-50mm
2333-601	40-60mm

2333-E04	0-0.4"
2333-E08	0.4-0.8"
2333-E12	0.8-1.2"
2333-E16	1.2-1.6"
2333-E20	1.6-2.0"
2333-E081	0-0.8"
2333-E121	0.4-1.2"
2333-E161	0.8-1.6"
2333-E201	1.2-2.0"
2333-E24	1.6-2.4"

It is necessary to set the original data before measuring. Find a gage block which is within the measuring range of the outside dial caliper gage. Clean the surface of the gage block and the measuring tips of gage. Sway the tips of the gage and find the minimum reading. Rotate the bezel of the gage to set the reading same as the value the gage block. Measure the gage block again and be sure the reading of the gage is the same as the value of gage block.



MN-2222-E