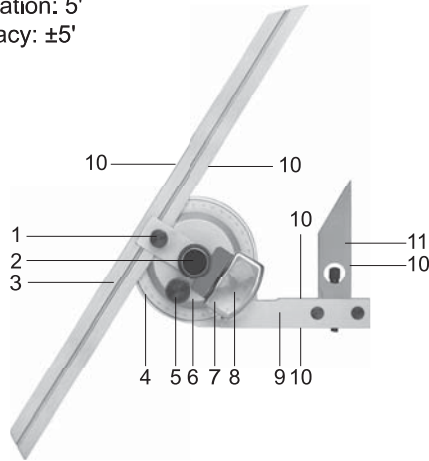


Graduation: 5'
Accuracy: ±5'



- 1-Fixture block
- 2-Brake
- 3-300mm blade
- 4-Main scale
- 5-Fine adjustment
- 6-Dial plate
- 7-Magnifier
- 8-Vernier scale
- 9-Base
- 10-Measuring faces
- 11-Angle attachment

13-Clamp for height gauges (Optional accessory, code: 2372-CLAMP)

1. Install blade and angle attachment:

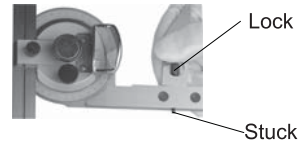
- Loosen fixture block
- Install blade, insert blade along the slot (fig 1), lock fixture block
- Install angle attachment as the fig 2 if needing it during measurement



fig.1

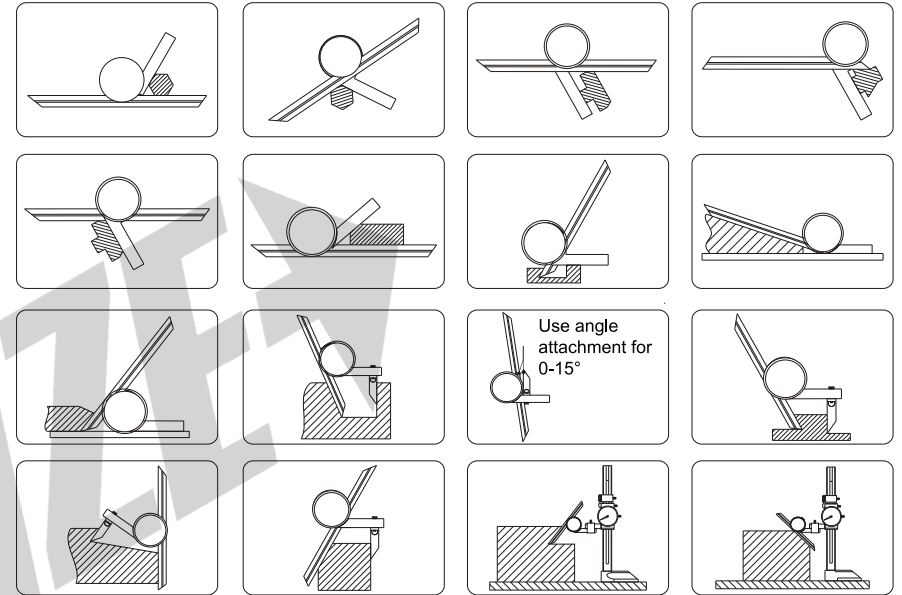


fig.2



2. Please clean the measuring faces with soft cloth before measurement, avoid dust or sundry to effect the results.

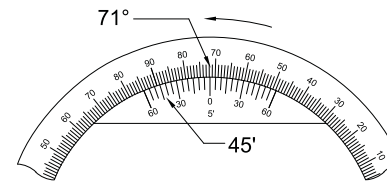
3. Measurement diagrams:



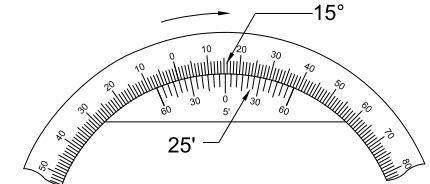
4. The reading is obtained by adding the reading of the vernier scale to that of the main scale. Take the vernier scale reading at the graduation which coincides with the one on the main scale. Details please refer to following figures.

Vernier scale increases counterclockwise to main scale after '0' graduation in vernier scale, read the left side of vernier scale.

Vernier scale increases clockwise to main scale after '0' graduation in vernier scale, read the right side of vernier scale.



Main scale reading: 71°
Vernier scale reading: 45'
Reading: 71°45'



Main scale reading: 15°
Vernier scale reading: 25'
Reading: 15°25'