



## OPERATION INSTRUCTION

### Three Points Internal Micrometer Series 3228

Graduation: 0.001mm

Code	Range	Accuracy	Setting ring
3228-70	50-70mm	5 $\mu$ m	$\Phi$ 50mm
3228-100	70-100mm	5 $\mu$ m	$\Phi$ 70mm
3228-150	100-150mm	6 $\mu$ m	$\Phi$ 100mm
3228-250	150-250mm	8 $\mu$ m	$\Phi$ 150mm
3228-300	200-300mm	9 $\mu$ m	—

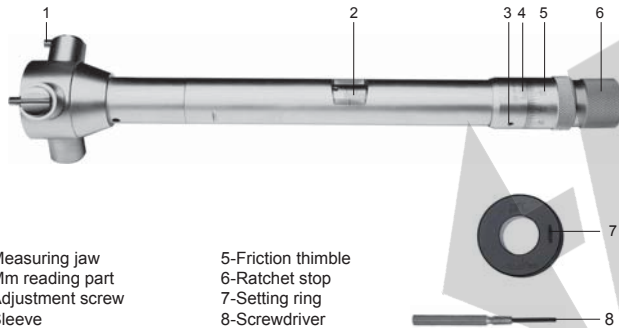

1-Measuring jaw  
2-Mm reading part  
3-Adjustment screw  
4-Sleeve

5-Friction thimble  
6-Ratchet stop  
7-Setting ring  
8-Screwdriver

1. The micrometer is used for measuring internal diameter.

2. Before measurement, it is necessary to calibrate the micrometer with setting ring. Clean the measuring faces and setting ring hole with soft cloth, then measure the size of the setting ring hole. The reading should be equal to the size of the setting ring hole. If there is a small deviation, please set the reading. Using screwdriver to loosen adjustment screw, then rotate sleeve until reading is equal to the size of the setting ring hole, lock the adjustment screw. The micrometer should be calibrated regularly.

3. During measurement, please make the micrometer measurement range a little smaller than the workpiece hole, then put the micrometer into workpiece hole vertically. It is necessary to hold the micrometer steadily by one hand, rotate friction thimble by the other hand, sway the micrometer wiggly to make the measuring faces be in contact with the workpiece hole until you hear click.

Caution: when the measuring faces are about to contact with the workpiece hole, please do not apply excessive force to rotate the friction thimble, which will lead to measurement error and may damage internal precision threads.

4. The reading should be the sum of the mm reading part, sleeve and friction thimble. Take the follow figure as an example, the reading should be 70.697mm.

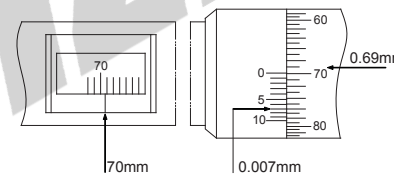

Mm reading part reading: 70 mm  
Friction thimble reading: 0.69 mm  
Sleeve reading: 0.007mm  
Reading: 70.697mm

MN-3228-E