

OPERATION INSTRUCTION

Concentricity Gauge

Series 4789

| Code | Applicable diameter | Accuracy |
|--------|---------------------|----------|
| 4789-1 | Ø3.5-25mm | 2µm |
| 4789-3 | Ø1-25mm | 2µm |

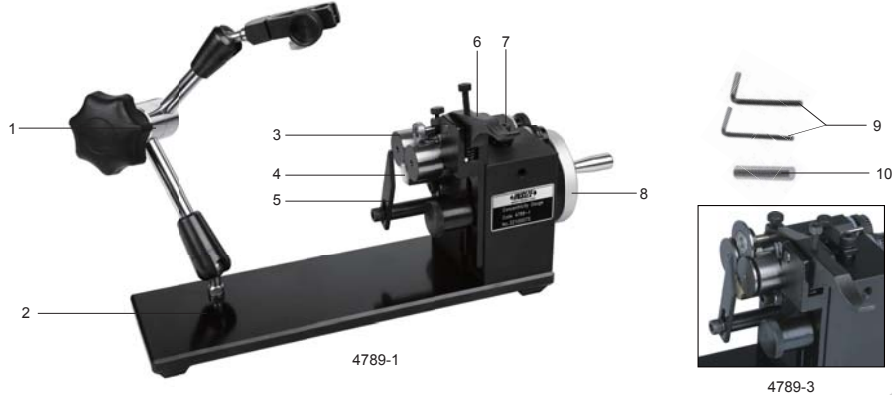

- 1-Indicator holder
- 2-Base
- 3-Cylinder
- 4-Dustproof brush
- 5-Baffle
- 6-Press device
- 7-Thimble
- 8-Hand-wheel
- 9-Wrench
- 10-Standard pin gage

1. Concentricity gage is mainly used to measure cylindrical workpiece's roundness and concentricity.

2. Description of each part:

Press device: Fix the workpiece with the pressure roller. The holder can be moved up and down, fix it by the locking screw. Pressure roller can be moved left and right, fix it by the pressure roller locking screws.

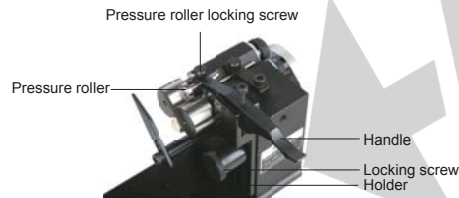

Baffle: Put it at the left end of the workpiece to prevent workpiece from moving left. The baffle can be moved up and down, fix it by the clamping screw, it can also be moved left and right, or along the axial, fix it by locking screw.

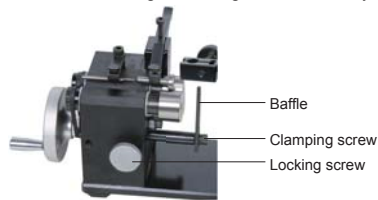

Thimble: Put it at the right end of the workpiece to prevent workpiece from moving right. Thimble can be moved left and right, fix it by clamping screw. Holder can also be moved up and down, fix it with hex wrench tightening the locking screw.

Hand-wheel: Move the workpiece by rotating hand-wheel.



Indicator holder: Clamp the indicator to fix it. Clamp the indicator by dovetail groove or stem hole, the direction of fine adjusting movement is contrary to the direction of the measuring point by force, which avoids to affect the result. Loosen locking wrench, arm and locking device can move freely, tighten it after setting its position.

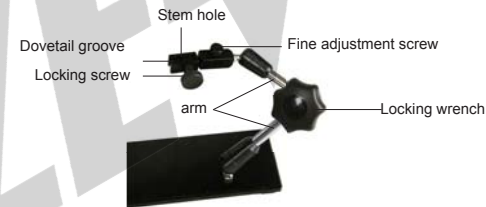

3. Measurement:

- It is necessary to clean faces of cylinder, pressure roller, workpiece before measurement
- Measure standard pin gage, cylinder accuracy<2µm, remove pin gage, and then measure workpiece
- Dial test indicator should be prepressing, the direction of the measuring point is close the workpiece's axes as far as possible, rotate hand-wheel, get the result till the pointer is steady



4. Notice:

- When clamp the workpiece, the outside length of workpiece should be less than 25mm
- The moment that start to turn hand-wheel, the pointer of indicator is jumping. Get reading after the pointer is steady
- Measuring faces should be carefully protected from being scratched or damaged. It should be oiled to prevent rust after use

5. Optional accessory: Dial test indicator(code: 2880-02, 2880-02R), mini magnetic stand (code 6224-40).