



# OPERATION INSTRUCTION

## Welding Gage Code 4840-1



# 使用说明书

## 4840-1 焊接规

| Graduation | Accuracy |
|------------|----------|
| 0.2mm      | ±0.1mm   |

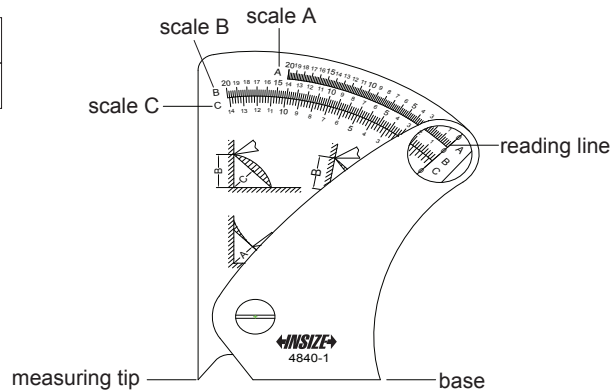

| 分度值   | 精度     |
|-------|--------|
| 0.2mm | ±0.1mm |

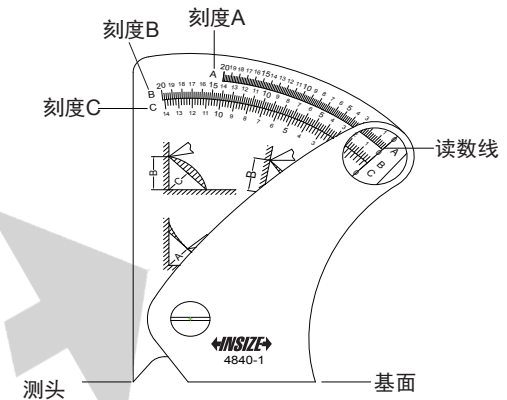

Measuring purpose

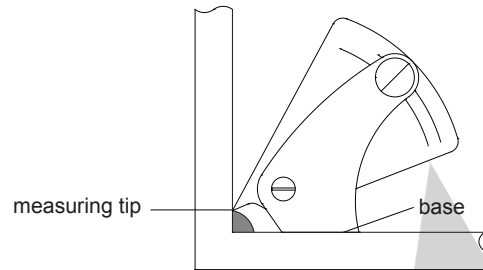

测量方法:

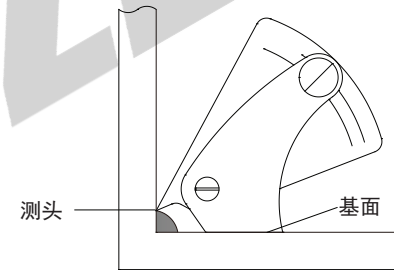

Reading: A means scale A, B means scale B, C means scale C

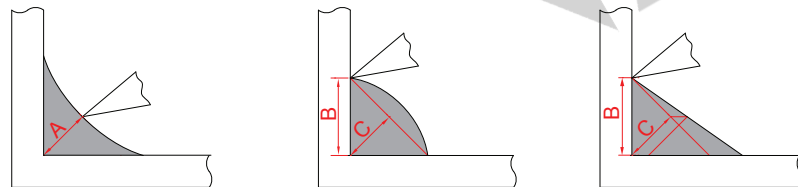

读数: 图示尺寸A、B、C分别对应刻度A、刻度B、刻度C读数

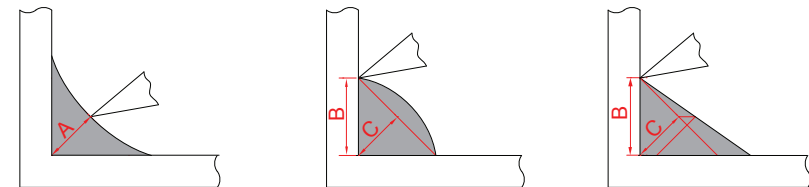

MN-4840-C/E

V0

MN-4840-C/E

V0