

Code	Magnetic force	Applicable holding stem	Remark
6200-60	60kgf	Φ8mm, Φ4mm, 3/8" DIA.	without fine adjustment
6201-60	60kgf	Φ8mm, Φ4mm, 3/8" DIA.	with fine adjustment
6202-80	80kgf	Φ8mm, Φ4mm, 3/8" DIA.	with fine adjustment
6202-100	100kgf	Φ8mm, Φ4mm, 3/8" DIA.	with fine adjustment

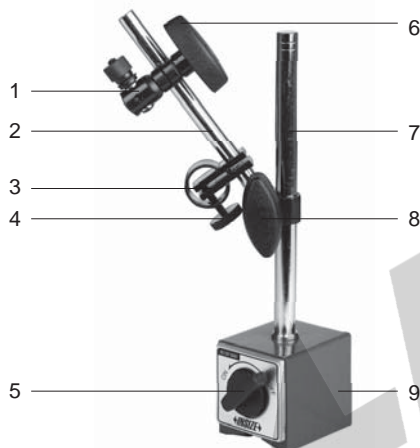

- 1-Holding device
- 2-Vice pole
- 3-Fine adjustment device
- 4-Fine adjustment screw
- 5-Magnetic switch

- 6-Holding locking wrench
- 7-Main pole
- 8-Locking wrench
- 9-Magnetic base

1. This magnetic stand is for digital/dial indicators and dial test indicators.
Holding as follows:



holding lug back



holding stem Φ8mm



holding stem 3/8" DIA.



holding dial test indicator
through Φ4mm clamp

2. Usage:

- Holding indicator as above ways
- Let the magnetic base be in contact with the machine tool, then turn on the magnetic switch to make sure that the magnetic stand can contact with the machine tool steadily.
Caution: Please make sure that the magnetic base and machine tool are cleaning, otherwise, the magnetic stand may be slide slightly during measurement, which will affect the measuring results.
- Loosen the locking wrench to adjust the vice-pole and indicator to the appropriate position. Rotate fine adjustment screw is convenient to operate when the indicator close to the workpiece. After adjustment, please make sure each part is locked steadily.
- After measurement, turn off the magnetic switch, magnetic base can be removed from the machine tool.

3. To get accurate measurement, please try to avoid using the magnetic base in vibration environment.