



www.insize.com

INSIZE



ISH-MRD200
AUTOMATIC DIGITAL
ROCKWELL HARDNESS TESTER
OPERATION MANUAL



Attention

- 1 . Do not touch the test force dial when loading.
- 2 . It is necessary to use one-way three-core plug to supply power, and should follow the rules of local protection.
3. Take off the weight ,indenter and fix the lever inside before move the hardness tester. And remember to restore the original packaging and safeguard procedures before long-distance transport.



Introduction

ISH-MRD200 is supplied with auto-load/unload test force part and is suitable for measuring Rockness hardness of carbide steel, carbon steel, alloy steel, cast iron and nonferrous metal etc.

Structure

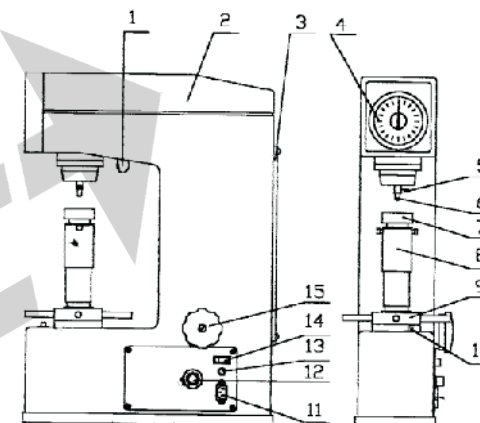

- 1.light 2.up cover 3.back cover 4.operational panel 5.lock screw of indenter 6.indenter 7.stage 8. case of lifting screw 9.lifting handwheel 10.start button 11.power supply hub 12.load dwell time adjustment 13.fuse 14.on/off button 15.test force dial

Installation

- 2.1 Unpacking and installation:
- a. open the wooden box, take out the protection bubbles and accessory box.
 - b. open the hardness packaging bag, take out dust cover and operation manual etc.
 - c. remove two M10 screws on the base board as picture 1, to move the hardness tester.
 - d. the hardness tester should be put on a stable stage after unpacking, and take the base when moving. And the levelness of the stage should be no more than 1mm/m.

Attention:

If test sample height over 40mm, it is necessary to make a circular hole with 70~80mm diameter to make the the lifting screw move up and down smoothly. The limited position of the screw going down is 220mm below the stage, and nothing in this area. The place of the hole is against the base as per picture 2 shows.



Picture 1

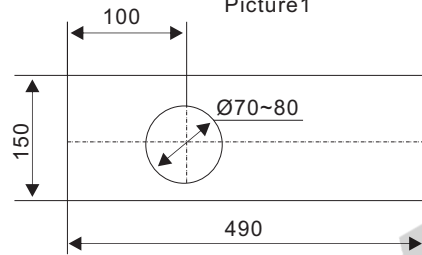

Picture 2

e. open the up cover and back cover after fixed the hardness tester, remove the galloon and bungee which used to fix the tester. And loosen the case of lifting screw, rotate the lifting handwheel to make screw go down, then take out the shockproof pads, and put on the stage.



fix lifting handwheel

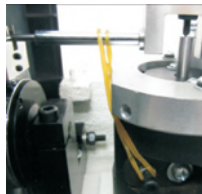

fix the header bar



fix the farmer derrick



fix the lever

f Install the weight:

Attention: Do no connect to power when installing the weight.

- 1) Take out the weights from the accessory box(There is A, B, C marked on the weights)
- 2) Rotate the test force dial to 588N, then take out the derrick and remove the nut.



- 3) Put the weight A to the derrick, then tight the nut and put the derrick to the original place
- 4) Put weight B and C to the corresponding position.
- 5) Change the loading and observe if the weights put in to the grooves, it is working well when weights move smoothly.

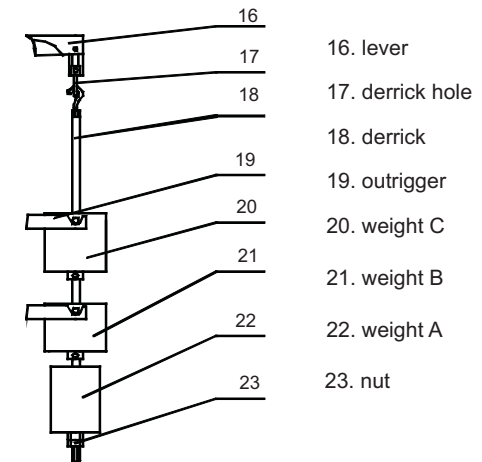

scale, test force and weight application form

scale	test force(N)	weight
HRA/HRF	588	derrick + weight A
HRB/HRD	980	derrick + weight A + weight B
HRC/HRG	1471	derrick + weight A + weight B + weight C

g after installation, put the up cover and back cover on.

Usage

3.1 Preparation before use

- a. Choose the right stage according to the shape and size of the test sample.
- b. Choose indenters and forces according to the material and hardness scale(as below table shows).

scale	indenter	test force(N)	Material(example)
HRA	diamond taper indenter (cone angle120°)	588	carbide steel, surface carburizing and quenching steel
HRB	ball indenter (ball dia.=1.5875mm)	980	mild steel, aluminum alloy, copper alloy, malleable iron, annealed steel
HRC	diamond taper indenter (cone angle120°)	1471	annealed steel, tempering steel, alloy steel, stainless steel
HRD	diamond taper indenter (cone angle120°)	980	sheet steel, case-hardening steel
HRF	ball indenter (ball dia.=1.5875mm)	588	magal, mild cast iron, thin mild steel plate, annealed copper alloy
HRG	ball indenter (ball dia.=1.5875mm)	1471	phosphor bronze, beryllium bronze, malleable iron

- c. Install indenters: put the indenter to spindle hole, ensure the spindle hole, end face, end handle of indenter and shaft shoulder clear with nothing. Tighten the lock screw at the end handle of indenter.

Attention: take the indenter tip with fingertip when installation to avoid the indenter falling down and cause indenter tip damaged.



- d. Rotate the test force dial to choose test force.

Attention: choose test force should go on under unload state.

- e. Adjust load dwell time to five seconds from adjusting “+” and “-” buttons.



- f. The measuring surface of the test material should be clear and without greasy dirt, oxide skin, grooves or clear machining traces, and the roughness of the measuring surface no more than 0.8μm is proposed.

3.2 Hardness Test

- a. Switch on the power, turn on the tester, light on to turn on the digital display screen.
- b. Choose the right scale, quantity and conversion value.

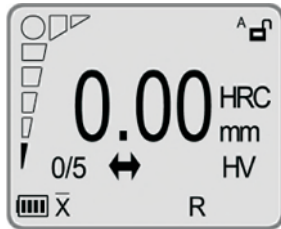

- c. Put the test material on the stage, and rotate the lifting handwheel along the pointer to move up the stage.

Attention: Rotate the handwheel lightly and equably to avoid the test material hit the indenter heavily and cause the indenter damaged.

- d. When the indenter touches the test sample, the figures on the display would increase, and the spline fit on the left would also move. When the circle at the end of the spline fit become solid, the test force finishes loading, and the header would automatic clear.

- e. Press the start button, then the light off, and the tester would start to load and load dwell time. When the light on again, the result could be read because the test force has been removed.

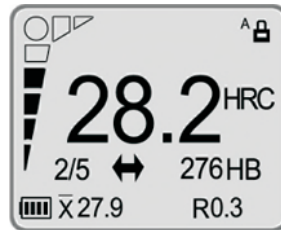

Attention: The first measurement or change indenter, stage, test sample, the first or second measuring result would not be as a reference. And the distance of adjacent indentation center would not be less than 2mm, the distance of any indentation center and the test material margin could not be less than 1mm.

- f. When finish reading results, rotate the lifting handwheel anti-clockwise to rise down the stage, and the measurement is over.

- g. If the measuring surface is an cylindrical surface with diameter less than 38mm, the measuring result should be revised, and the actual hardness value is equal to the measuring result plus the correction.

Hardness value (HRB)	Diameter of cylindrical surface(mm)						
	6	10	13	16	19	22	25
	Correction of Rockwell B scale						
20				4.5	4.0	3.5	3.0
30			5.0	4.5	3.5	3.0	2.5
40			4.5	4.0	3.0	2.5	2.5
50			4.0	3.5	3.0	2.5	2.0
60		5.0	3.5	3.0	2.5	2.0	2.0
70		4.0	3.0	2.5	2.0	2.0	1.5
80	5.0	3.5	2.5	2.0	1.5	1.5	1.5
90	4.0	3.0	2.0	1.5	1.5	1.5	1.0
100	3.5	2.5	1.5	1.5	1.0	1.0	0.5

Hardness value (HRC) (HRA)	Diameter of cylindrical surface(mm)								
	6	10	13	16	19	22	25	32	38
	Correction of Rockwell A/C scale								
20				2.5	2.0	1.5	1.5	1.0	1.0
25			3.0	2.5	2.0	1.5	1.0	1.0	1.0
30			2.5	2.0	1.5	1.5	1.0	1.0	0.5
35		3.0	2.0	1.5	1.5	1.0	1.0	0.5	0.5
40		2.5	2.0	1.5	1.0	1.0	1.0	0.5	0.5
45	3.0	2.0	1.5	1.0	1.0	1.0	0.5	0.5	0.5
50	2.5	2.0	1.5	1.0	1.0	0.5	0.5	0.5	0.5
55	2.0	1.5	1.0	1.0	0.5	0.5	0.5	0.5	0
60	1.5	1.0	1.0	0.5	0.5	0.5	0.5	0	0
65	1.5	1.0	1.0	0.5	0.5	0.5	0.5	0	0
70	1.0	1.0	0.5	0.5	0.5	0.5	0.5	0	0
75	1.0	0.5	0.5	0.5	0.5	0.5	0	0	0
80	0.5	0.5	0.5	0.5	0.5	0	0	0	0
85	0.5	0.5	0.5	0	0	0	0	0	0
90	0.5	0	0	0	0	0	0	0	0

Attention: If the diameter is not included above, interpolation method is proposed.

For example:

If the measuring surface is an 8mm cylindrical surface, the correction can be worked out when the measuring hardness value is 60HRC.

It is easy to find when the hardness value is 60HRC, the correction of 6mm and 10mm is 1.5 and 1.0, so 1.25 could be recognized as the correction pf 8mm cylindrical surface.

g. The minimum of the test sample thickness should be more than ten times of the depth of indentation. After test, the back of the test material should has no visible deformation traces. And the relationship of the test sample minimum thickness and hardness value could be found as per below form:

HRA	Hardness value	20	30	40	50	60	70	80	90	
	Mini-thickness	1.6	1.4	1.2	1.0	0.8	0.6	0.4	0.2	
HRB	Hardness value	20	30	40	50	60	70	80	90	100
	Mini-thickness	3.3	3.0	2.7	2.4	2.1	1.8	1.5	1.2	0.9
HRC	Hardness value	20	30	40	50	60	70			
	Mini-thickness	1.6	1.4	1.2	1.0	0.8	0.6			

Remark: the unit of mini-thickness is mm.

Maintenance

4.1 Keep clean and away from dust, corrosion and rust in daily work or after using the hardness tester.

4.2 Be careful when install or take off the indenter, and grease is also needed if not used for a long time, keep it well.

4.3 The stage and the hardness standard block should be clean, flat, or any no scratch, paint some antirust grease before store.

4.4 The lifting screw should be lubricated regularly. The detail operation: take off the stage and the case of screw, paint some antirust grease on the screw, then rotate the lifting handwheel to lift the screw up and down, so the grease could be uniform. At this moment, you can put the case and stage back.

4.5 Check the indentation error and repeatability with hardness standard block regularly. If the value out of range, need to check if any wrong with the hardness tester.

Attention: The surface with words marked on the hardness standard block is the measuring surface.

required indentation error and repeatability

scale	hardness range	indentation error	repeatability
HRA	20~75HRA	±2HRA	≤1.5HRA
	75~88HRA	±1.5HRA	
HRB	20~45HRB	±4HRB	≤1.5HRB
	45~80HRB	±3HRB	
	80~100HRB	±2HRB	
HRC	20~70HRC	±1.5HRC	≤1.5HRC

4.6 If something unusual happens to the hardness tester, do not disassemble or adjust any structure, please contact us to solve this problem.