



www.insize.com

INSIZE



**ISHR-M111
MAGNETIC ROCKWELL HARDNESS TESTER
OPERATION MANUAL**



Attention

- ◆ This Instruction Manual shall be carefully read through in prior to use of the apparatus to clearly understand the detailed operation steps and special notes, and avoid apparatus damage or personal injury caused by improper use.

Description

- 1 ISHR-M111 Magnetic Rockwell hardness testers comply with the basic designing principles of Rockwell harness testing in accordance with international standard ISO6508, American Standard ASTM E110.
- 2 The hardness values can be read directly from the Rockwell hardness testers after rapid and accurate operations. It can be considered as a non-destructive testing with very small indentations. This kind of testers can be used at the production site to test piece by piece the finished and semi-finished work pieces produced in batch. Rockwell hardness testers are mostly applied in the metal-processing enterprises.

Principle and Structure

- 1 The indenter is pressed (diamond cone or carbide ball) into the specimen surface in two steps. After maintaining the pressure for a predetermined period of time, unload the major test force F1, and measure the remaining indentation depth h under initial test force F0.
- 2 Rockwell hardness value is:

$$HR=N - \frac{h}{S} \dots\dots\dots (1)$$

In this equation:

N — a constant related to scales; for A, C scales, N=100; for B scales, N=130.

S — unit indentation depth, for Rockwell hardness it is 0.002mm.

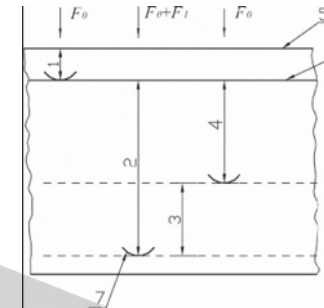

- 1 — indentation depth under initial test force F0;
- 2 — indentation depth under total test forces F0+F1;
- 3 — elastic recovery depth when major test force F1 is removed;
- 4 — remaining indentation depth h;
- 5 — test piece surface;
- 6 — datum plane;
- 7 — position of indenter

- 3 Rockwell hardness testers are designed according to the basic principle of Rockwell hardness test. The main differences from the bench-type lie in: the test force is applied by a screw and a calibrated U-shape spring; two indicators are installed on the tester: one indicating dial indicates the test force value by measuring the deformation of the spring and one precision screw micrometer used for testing the indentation depth; one barrel dial installed on the micrometer shows the hardness values.

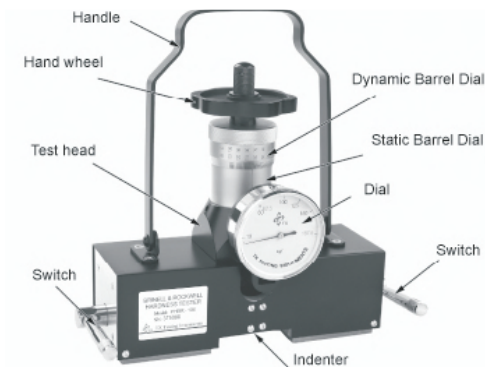

Main Technical Parameters

Initial test force: 10kg

Test force: 30, 100, 150kg

Maximum magnetic force: 350kg

Force applying method: by screw

Indenter: 120°diamond cone, Ø1.588mm carbide balls

Testing Items: HRC, HRB, HRA

Resolution: 0.5HR

Accuracy: Meets the requirements of ISO6508/6506

Application: All metals, including steel, forged steel, cast iron, copper, copper alloy, aluminum, aluminum alloy and carbides etc.

Selection of Indenter, Test Force and Anvil

- 1 The indenters should be selected according to the hardness range of testing materials.
Select diamond indenters for tempered steel, quenched steel, surface hardening steel and carbides; ball indenters for soft metals.
When the hardness of test samples cannot be estimated, a diamond indenter should be used first to test HRC. When the hardness value is smaller than a certain relevant testing range, the ball indenter can be applied.
The following requirements should also be taken into account:
 - a. Do not use the ball indenter to test quenched steel and carbides.
 - b. Choose the suitable ball indenters based on the hardness of test pieces when testing soft materials so as to make the test results lie within the test range of relevant scales.
 - c. Prevent the indenter from damaging the anvil when testing thin materials.
 - d. The diamond indenter and the diamond spot anvil can not be used at the same time.

- 2 The test force should be selected according to the thickness of the test piece.
Apply big test force to thick test pieces, small test force to thin test pieces and use superficial Rockwell hardness tester to test thinner specimens.
Also follow the principles below when choosing test forces:
 - a. When different test forces are applicable for a certain test piece, choose the biggest test force among them, because big test force can make deep indentations and the accuracy will be higher.
 - b. When testing thin specimens, no visible deformation trace should be observed on the back side of specimens, otherwise, it means the test force is overloaded with measuring anvil effect and it should be reduced.
 - c. Do not use C scale with the big test force to test carbides. Otherwise, the diamond indenter will be damaged.
- 3 The anvil should be selected according to the shape of the test piece.
Flat anvils are adopted by flat specimens.
V-shape anvils are used to test specimens with a cylindrical surface thick wall pipes, round bars and wires.
According to the design of the magnetic type hardness tester, it is applicable to the specimens of flat surface or curved-surface with outer diameter>300mm requiring that the test side of the instrument should have surface contact with the specimen surface.
When test on such curved-surface specimens with outer diameter 100mm~300mm as tubes, bars and rings etc. is needed, the outer diameter values should be submitted to the manufacturer and the manufacturer will prepare and tailor-make the special adapters for the instrument. After the adapter is installed on the instrument, test on the curved-surface specimen with relevant diameter can be carried out immediately.

Operation

- 1 Test Conditions:
 - a. Magnetic Type Rockwell Hardness Testers can be used only for testing iron and steel.

b. When testing on specimens with the flat surface, the specimen area should be greater than 60mm×180mm; while testing on specimens with the curved-surface, the specimen diameter should be greater than 100mm.

c. Thickness of the specimen should be > 5mm.

d. The bottom of the instrument should contact the surface of the specimen well. Adapters of proper sizes should be installed when testing on the curved-surface specimens.

e. The specimen surface should be smooth since the rough surface can reduce the magnetic force. It does not matter if there are some shallow cutting lines on the specimen surface, but the rough surface by casting and forging should be tested after ground smooth.

2 Preparations:

This instrument has strong magnets. The magnetic switch should be set at "Release" when it is idle and the magnet is inactive. Only when the instrument is firmly placed on the ferrous specimen and ready for test, can the magnetic switch be set at "Attract". Otherwise, the instrument can be damaged and bodily injury may happen.

Check the magnetic switch before test and ensure it is set at "Release". If not, place the magnetic switch at "Release" immediately.

Also confirm that the proper indenters are selected before test. Diamond indenters are used for testing the quenched, tempered ferrous parts; ball indenters are used for testing annealed, normalized ferrous parts. The instrument is installed with a diamond indenter before leaving factory.

3 Fix the Instrument:

When testing the specimen with a flat surface or curved-surface with bigger outer diameter, the instrument should be placed smoothly on the surface and the two magnetic switches should be set at "Attract" position one by one, then the instrument will be firmly attracted on the specimen.

When testing the curved-surface specimen with smaller outer diameter, the adapter should be installed first. The adapter is composed of four pieces of iron. On each iron piece there are two surfaces with screw holes; one is flat, the other is a crown face. The curvature radius of the crown face is the same with that of the specimen. Lean the flat side of

the adapter against the test side of the instrument and keep the curved surface connected, then fasten the adapter with screws.

Place the instrument firmly onto the curved specimen. Surface contact between the test side of the instrument and the specimen can be realized by the help of the adapter.

Set the two magnetic switches at "Attract" side one by one, meanwhile the instrument should be attracted onto the specimen firmly.

4 Set "0" to the Force Indicator:

Check the position of the indicator hand; it should rest on the red "0" point. If it does not rest on the red point, turn the dial bezel and bring it to the red point.

5 Applying Initial Test Force:

Rotate the hand wheel clockwise to bring the indicator hand to the initial test force "10kg".

6 Adjust the Barrel Dial:

Rotate the dynamic barrel dial anticlockwise to bring the full scale marks of it (the red line 130 and the black line 100) exactly aligned with the scale marks of the static barrel dial.

7 Applying and Removing the Main Test Force:

Successively and steadily rotate the hand wheel clockwise to bring the indicator hand of the load dial to the total test force $F = F_0 + F_1$ (e.g., for HRC scale, $F = 150\text{kg}$).

The time duration from applying the initial test force to applying the total test force should be no more than 8 seconds.

After applying the total test force, the main test force should be completely removed within 2 seconds and the indicator hand should be brought to the initial test force "10kg".

8 Take the Hardness Reading:

The harness number from where the scale mark on the dynamic barrel dial is aligned with that of the static barrel dial represents the hardness value of this test. Read the number and estimate the reading to 0.5 hardness unit.

For scales with the diamond indenters (e.g., HRA, HRC), take the reading on the black C scale of the dynamic barrel dial.

For scale with the ball indenter (e.g., HRB), take the reading on the red B scale of the dynamic barrel dial.

- 9 Withdraw the Indenter:
Rotate the hand wheel in a reverse direction after the test is finished to withdraw the indenter until the dynamic barrel dial retreats to where the red point on the static barrel dial is shown.
- 10 Remove the Instrument:
Set the two magnetic switches to "Release" position one by one to remove the instrument.
Attention: The switch handle should be turned by full 180° and exactly rest on the "Release" mark when setting the switch to "Release". Then the magnets of the instrument are completely inactive to the external objects.
- 11 Replace the Indenter:
The indenter probably needs to be replaced following the change of the test scales. Below is the operating method:
Rotate the hand wheel clockwise to show the parts of the indenter as many as possible.
Replace and screw tight the indenter. Rotate the hand wheel anticlockwise to move the dynamic barrel dial upward until the red point on the static barrel dial is shown out.
1 or 2 pretests should be made first after the indenter is replaced before starting the formal test.

This instrument has strong magnets which are active when the magnetic switch is set at "Attract" and inactive when the magnetic switch is set at "Release". In order to ensure safety, DO NOT set the magnetic switch at "Attract" when stored or transported at normal times after using the instrument, otherwise there will be intense attraction between the instrument and ferrous objects, which may result in injury to the operator's hands or malfunction to precision instruments like the wrist watch.

Inspection of Hardness Testers

Daily inspection should be made to the hardness tester with the standardized hardness blocks.
If the tester is used every day, it should be inspected daily; otherwise, it should be inspected every time before using. Daily inspection could be applied to only one scale to be used with one standardized hardness block.

Choose the standardized hardness block with its hardness most close to the hardness value of the test piece. When the daily inspection is carried out, test 5 times on the hardness block, neglect the first 2 data and take the average of the rest 3 data.

Cautions in Use

- For Rockwell hardness testers, except under normal testing, in any case the diamond indenters should not be pressed against the anvil, extension and specimen. Otherwise, it can be damaged.
- Indentations should not appear on the bearing surface of the specimen or the anvil work surface.
- During the test the direction of testing force must be vertical to the specimen testing surface, and when applying test force the specimen should not move or slide on the anvil.
- The process of applying force should be slow at even pace. The dial pointer should rise smoothly. If the pointer is found to be uncontrollably dithering or sliding down, the possible causes may be improper selection of the anvil or unstable support of the specimen, the relevant measures should be taken.

Maintenance

This tester is a precision instrument, the service life of which depends on correct usage and timely maintenance. This tester can be used for 20 years under proper maintenance and inspection conditions. Users should read carefully this instruction manual, master the inspection rules and operating methods after receive it. The tester should be inspected correctly, handled carefully, stored properly and used by a special person. It should be put in the carrying case after used. Pay special attention to the following points:

- Anti-rust:
Though all the parts of this instrument have been treated anti-rust, some parts still can be rusted by improper storage or maintenance, especially in the coastal areas.

The instrument has been fully lubricated before leaving the factory, so no lubricating should be made in use. It should be often wiped with a piece of soft cloth. Be careful to keep the anvil, indenter, extension and the hardness block dry and clean. The testing surface of the hardness block is not allowed to touch by hand.

2 Avoid falling off:

This instrument is made up of many precision components, impact or falling off of it will result in the permanent damage to some parts, even worse the instrument can be discarded as useless. The magnifier of this instrument is made of synthetic glass, and it can be broken by impact. Disassemble and store the magnifier separately during transportation to protect it. The force indicator should be protected from impact in use and during transportation as an important part of the tester. For the instrument with opening size of 1 inch, move away the hardness block which is nearest to the force indicator during transportation.

3 Disassembly forbidden:

The testing accuracy of this instrument is guaranteed by the good collaboration of some of the precision parts. This collaboration is not easy for the nonprofessional people to master. Consequently, disassembly of the parts is not allowed except for parts, such as the indenter, anvil and the extension, otherwise this will result in inaccurate instrument or some parts damaged, and the warranty will be void.