

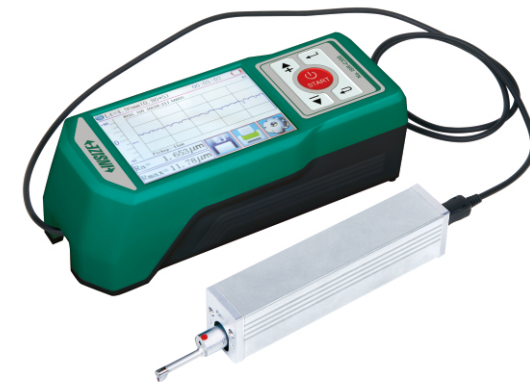

www.insize.com



**ISR-C300
ROUGHNESS TESTER
(SEPARABLE TYPE)
OPERATION MANUAL**



Introduction

The surfaces roughness tester is a small handheld instrument, for shop floor use and mobile measure, it operation simple, function overall, measure fast, accuracy stability, take convenience. This tester applies to production site and can be used to measure surface roughness of various machinery-processed parts. This tester is capable of evaluating surface textures with a variety of parameters according to various international standard. The measurement results are displayed digital/graphically on the color graphic LCD display, And output to the printer.

1 Features

- ◆ Composite structure of main display unit ,driver unit and Sensor. Electromechanical integration design, small size, light weight, easy to operation;
- ◆ Data can be output to Excel by connecting with computer via bluetooth or USB cable;
- ◆ Support Bluetooth printing and mobile APP wireless operation;
- ◆ Multi parameters: Ra, Rz, Rq, Rt, Rp, Rv, R3z, R3y, Rz(JIS), Rs, Rsk, Rsm, Rku, Rc, Ry, Rmax, Rmr;
- ◆ 320µm Large measurement range;
- ◆ The 3.5-inch color graphic LCD provides excellent readability and an intuitive display that is easy to negotiate. The LCD of 480*320 dot matrix includes a adjustable backlight for improved visibility in dark environments. Wide angle of view;
- ◆ DSP chip control and data processing, high speed, low power consumption;
- ◆ Display full information, intuitive and graphical displays all parameters;
- ◆ The tester Complies with the following standards:ISO-1997, DIN, ANSI, JIS2001;
- ◆ Built-in 3200mAh lithium-ion rechargeable battery and control circuit, high capacity, no memory effect;
- ◆ Can work more than 50 hours while the power is enough;
- ◆ Large capacity data storage, can store 100 item of raw data and measured profile;
- ◆ Real-time clock setting and display for easy data recording and storage
- ◆ With automatic sleep, automatic shutdown power-saving features;
- ◆ Reliable circuit and software design of prevent the motor stuck;
- ◆ Instrument can display a variety of information tips and instructions. For example Measurement result display, the menu prompts and error messages;

- ◆ Metal case design for driver unit, rugged, compact, portable, high reliability;
- ◆ Can connected to the computer and printer;
- ◆ All parameters can be printed or print any of the parameters which set by the user;

2 Measurement principle

When measuring roughness of part surface, the pickup is placed on the surface of the part and then tracing the surface at constant rate. The pickup acquires the surface roughness by the sharp stylus in pickup. The roughness causes displacement of pickup which results in change of inductive value of induction coils thus generate analogue signal which is in proportion to surface roughness at output end of phase-sensitive rectifier. This signal enters data collection system after amplification and level conversion. After that, those collected data are processed with digital filtering and parameter calculation by DSP chip and the measuring result can be read on LCD, printed through printer and communicated with PC.

3 Standard Configuration

Item	1pc
Standard probe	1pc
Calibration block and support	1pc of each
Connecting cable	1pc of each
Magnetic stand adapter	1pc
Adjustable stand	1pc
Touch pen	1pc
USB cable and software	1pc
AC/DC adapter	1pc

④ Name of each part

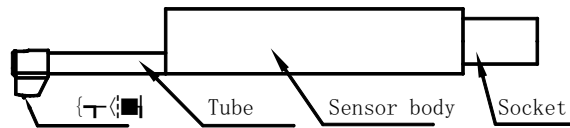

Sensor

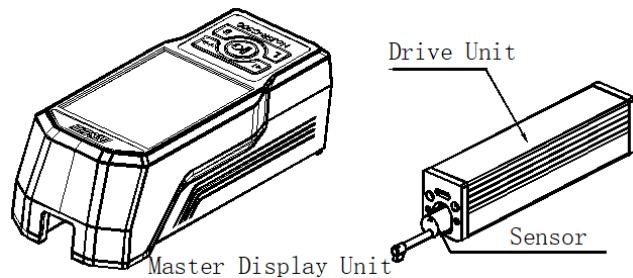

Front view

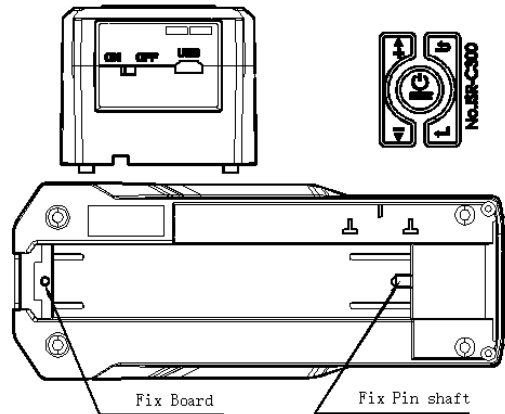

Power switch is a total power switch on the instrument. Turned off when not in use for a long time.

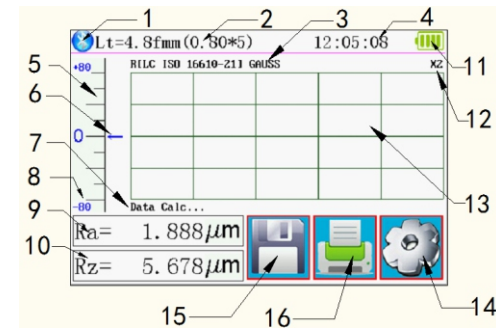

- 1 Bluetooth Mark; 2 Assess length; 3 Filter; 4 Working Time;
- 5 Start Touch key area; 6 Pickup position; 7 Hint information area;
- 8 Range; 9 Master results display; 10 Slave results display;
- 11 Battery level; 12 Profile scale; 13 Profile display area;
- 14 Menu touch key; 15 Save touch key; 16 Print touch key

⑤ Buttons define



- Power key: Press and hold START 2 seconds On/Off tester
- Start measurement key: Start the instrument to measuring
- Up /Add key: Increase the value
- Cancel / Exit key: Used to exit the menu and unset
- Enter key: Confirmation setting
- Down / decrease key: decreased the value

touch key of Hidden

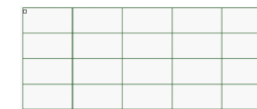
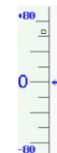

Ra= 1.888μm
Rz= 5.678μm

Start touch key Profile zoom touch key

Multi results and Profile touch key

6 Battery Charging

When battery voltage is too low (that is, battery voltage symbol display  on screen to prompt low voltage), the instrument should be charged as soon as possible. USB port of the instrument for charging. You can use the built-in power adapter for charging, you can also use computer's USB port for charging. If use the other power adapter for charging, the output voltage should be 5V DC , the current should be greater than 1000mA.

Instrument displays charging animation when charging after full animation ends, the display is full of symbols. Charging time of 5 hours.

This instrument adopts lithium ion chargeable battery without memory effect and charging can be fulfilled at any time without affecting normal operation of the instrument.

7 Connection method of sensor and drive unit

When installing and remove sensors, turn off the power first.

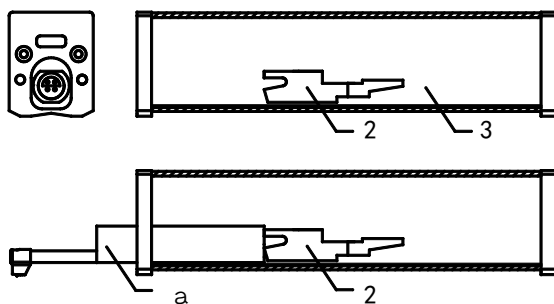

1 sensor 2 Socket of drive unit 3 Drive unit

For installation, hold the main body of sensor with hand, push it into socket at the the drive unit as shown in Figure and then slightly pushed it to the end of the sheath. To remove, hold the main body of sensor or the root of protective sheath with hand and slowly pull it out.

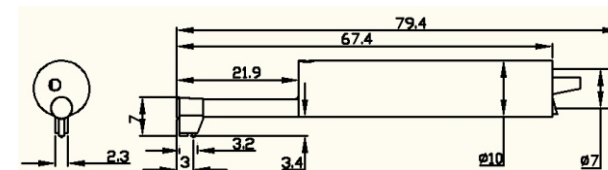
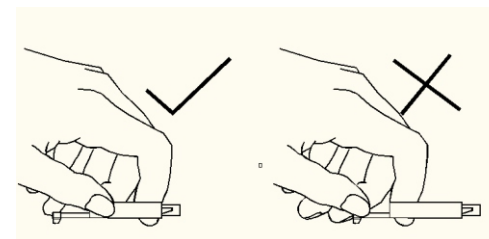

1. Sensor is key part of this tester and great attention should be paid to it.
2. During installation and remove, the stylus of sensor should not be touched in order to avoid damage and affecting measurement.
3. Connection of sensor should be reliable during installation.
4. The sensor doesn't need to be removed when not in use.
5. Calibration is recommended after each new sensor is installed.

8 Connection method of Drive unit and Main Display unit

Installation method

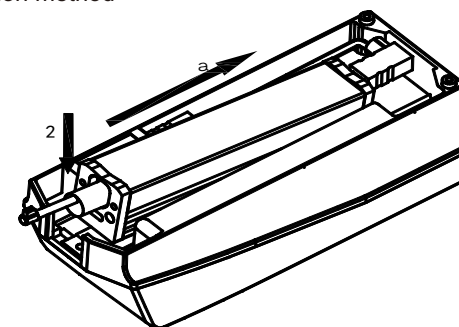

- 1 The driver unit is embedded into the main display unit according to the direction of arrow 1, so that it is installed on the fixed pin shaft.
- 2 Press the drive unit in the direction of arrow 1 and down the direction of arrow 2 to install the driver unit on the fixed plate.

Remove method

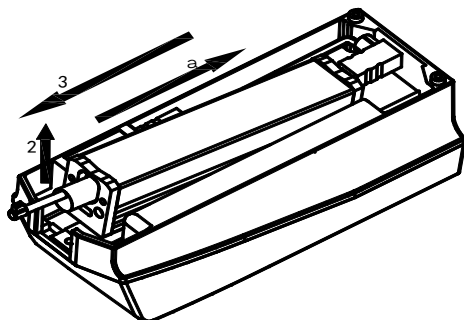

- 1 Press the driver unit toward arrow 1 and lift it toward arrow 2. Remove the driver unit from the fixed plate.
- 2 Pull the driver unit in the direction of arrow 3 and take out the drive unit.

9 Extension cable usage

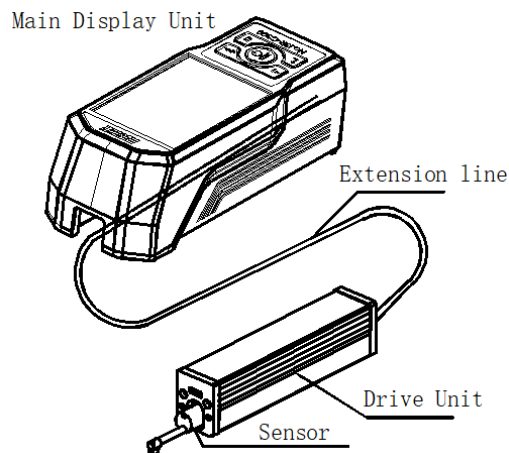

If the drive unit is not installed on the main display unit, please connect the main display unit and the drive unit with the extension cable as shown in the following figure before using it.

Measuring Operation

1 Preparation for Measurement

- Switch-on to check if battery voltage is normal;
- Clear the surface of part to be measured;
- Place the instrument correctly, stably and reliably on the surface to be measured;
- Trace of the pickup must be vertical to the direction of process line of the measured surface.

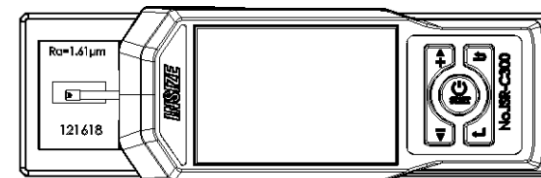

2 Turning On/Off

- Press the POWER key to hold 2 seconds after the instrument will automatically boot, boot will display type, name and manufacturer information, and then enter the basic measurement status main display interface.
- In any state, press the POWER key to hold 2 seconds after the instrument will be turned off.

Introductions:

1. The next boot will be displayed when the last shutdown set content.
2. Startup and shutdown, press and hold the key for about 2 seconds to open the instrument will perform the appropriate action.
3. Long time not to use, the instrument should be on the side of the power switch turned off.

3 Pickup Position

- First, view pickup position to determine the location of the sensor. The best location is in the middle position of the range.
- Arrow indicates if it is not at zero point. The instrument can also be measured normally.
- As long as the entire measurement process does not exceed the set range, it will not affect the measurement results.

4 Start measurement

In the main interface display mode, Press the Start key or Start key touch area to start measuring. The measurement can be stopped according to ESC.

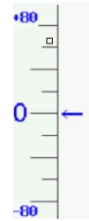

5 Measurement result display

After the measurement, if you need to look at all the measurement results, touch the main and secondary display area will be able to see all the calculation results. The touch profile display area will zoom the profile by 1-2-4-8.

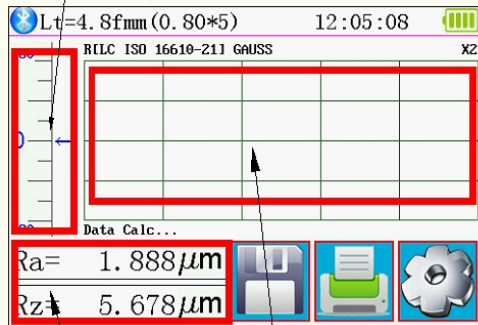

More results touch area Zoom key touch area

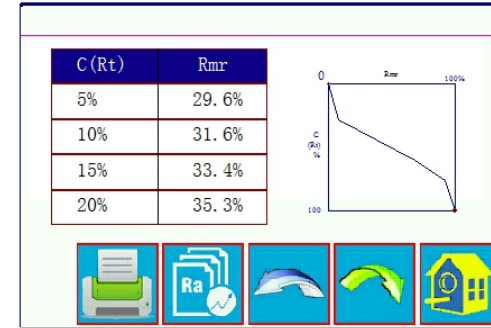
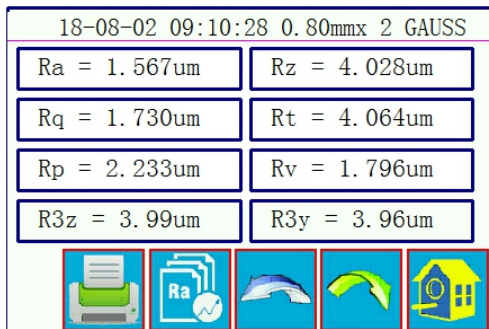

6 Print measurement results

The instrument can be connected to the printer. The measurement results will be printed. After measurement, Press key to print the measured data to a serial printer. The instrument can set the print output according to the actual requirements of arbitrary parameters choose to print or print all the parameters, how to set the parameters, refer to "Print Settings".

7 Storage measurement results

In the main display interface mode, press the key to save the measurement results stored in the instrument memory. Instrument built-in large capacity memory, can store 100 groups of raw data and profile data. Data storage recording date and time the file name automatically generated according to the last data record is always stored the most recent recording time, the last data record stored recording record number will be 001.

8 Setting Main Menu

In the main display interface mode, press the key enter main menu

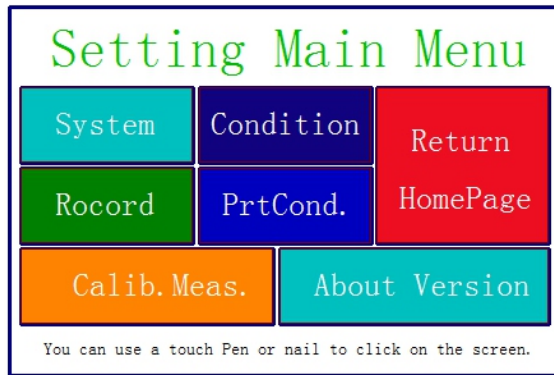

9 System Setting

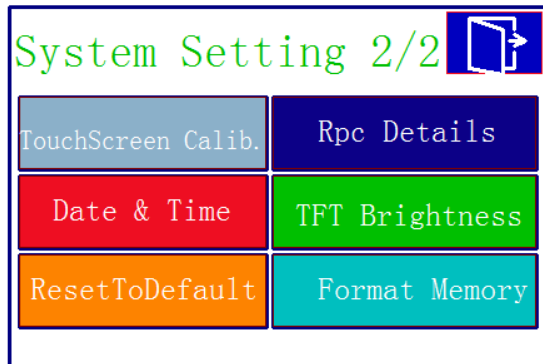
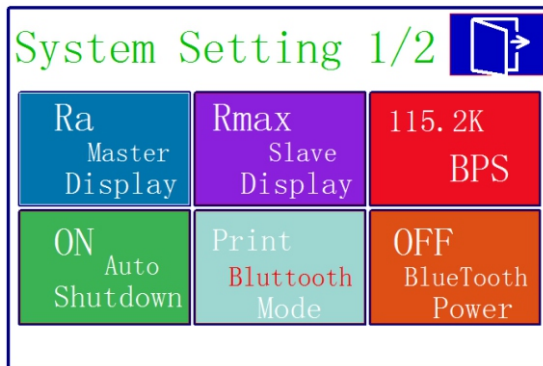

Touch system setting area can page up system settings.

1. Master results display and slave results display

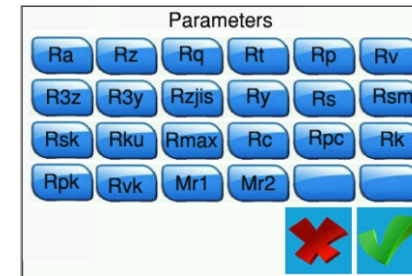

2. BPS rate setting

The BPS rate of communication between instrument and printer or between instrument and APP of mobile phone.
Default BPS rate 115.2K

3. Auto shutdown

Set to ON instrument for 600 seconds without operation will be automatically shutdown . When OFF is set, it will work all the time.

4. Bluetooth mode

There are 2 mode to operate Bluetooth module, print mode and data transmission mode.
Set it to print when Bluetooth printing is needed and to Ctrl when communicating with mobile APP
Bluetooth switch can only be operated when Bluetooth power is off.

5. Bluetooth Power

Please set the Bluetooth mode first, then turn ON the Bluetooth power, the instrument will automatically set the Bluetooth module as required.
Because of the unnecessary battery capacity loss caused by the long-term opening of the Bluetooth function, the instrument will turn off the Bluetooth power after each boot. If you need to use Bluetooth function, please open it yourself.

6. Touch Screen calibration

When the instrument is manufactured, the touch screen has been calibrated. Generally, calibration is no longer required, but the physical parameters will change over time. If you find that the button is not correct, please calibrate again. Please follow the screen prompts.

7. Rpc Details settings

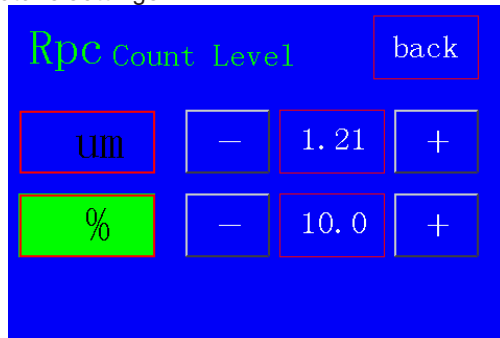

According to user's demand, Rpc-parameter's calculation can be selected from "μm" and "%".

8. Date and Time settings



If you want to change the date and time, please press STOP first, after the modification is finished, press START.

9. LCD Display brightness settings

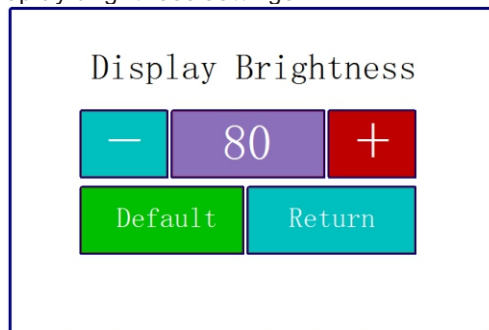

10. Reset factory settings



11. Format memory

Data formatting is the deletion of data records. Once formatted, all data will be emptied. Before the data formatting, the instrument has the confirmation prompt information. After the user confirms, the data will not be restored. Please proceed with caution. Format memory takes about 1 minutes, please do not turn off the power.

10 Measuring Condition Settings

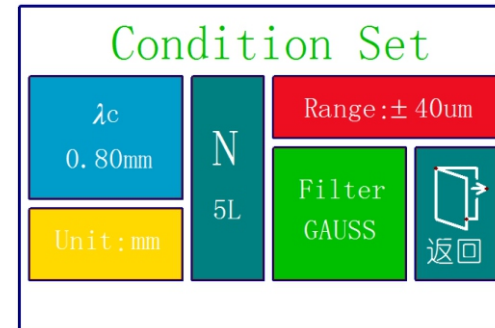

Cut off length λc	0.25mm;0.80mm;2.50mm
Number of Sampling lengths (×n)	1-5
Range	±20μm; ±40μm; ±80μm; ±160μm
Unit	Inch mm
Filter	RC;PC-RC;GUASS;D -P

11 Record Management

Click on the corresponding record to see the details of the record.

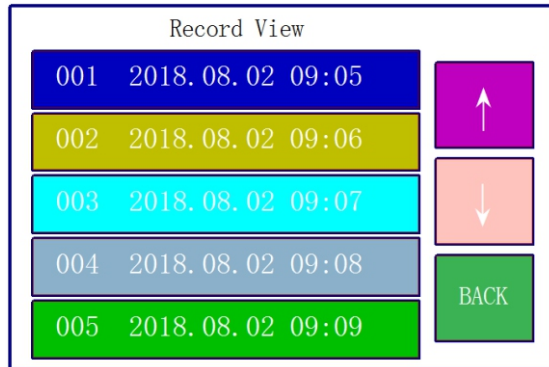

12 Software Information

Instruments software and hardware information can help users easily upgrade and maintain the product, unique serial number of the instrument software information items are displayed.

13 Parameter calibration

Before measuring, the instrument usually required calibration on standard calibration block. The instrument is configured with a standard calibration block, before measurement, instruments should test on the block. Under normal circumstances, when the difference between the measured value and the block value is in the acceptable range, the measurement value is valid, can be measured directly.

If the measured value and the block value which difference is greater than a accuracy error range of the instrument, or the user require high accuracy, can be used to correct the indication calibration function and improve measurement accuracy. The value of the calibration procedure is as shown.

Illustration is based on a model calibrated 1.63µm steps to calibrate the model for the actual calibration of the nominal value of the set value.



1. Under normal circumstances, the instrument in the factory have been rigorously tested, showing error is much less than ± 10%, in this case, the user is not showing the value of the calibration frequently used functions.
2. After setting the calibration value, you must press the START key for a full measurement, instrument calibration to be valid.
3. New parameters after calibration must be carried out once a complete measurement and press the Save&Exit key is stored in the instrument.
4. Press "Exit"key to return the menu without saving calibration results.

14 Print Function setup

The instrument can be tested according to the actual requirements of any parameter selection Print or Print All, the steps shown in Figure.

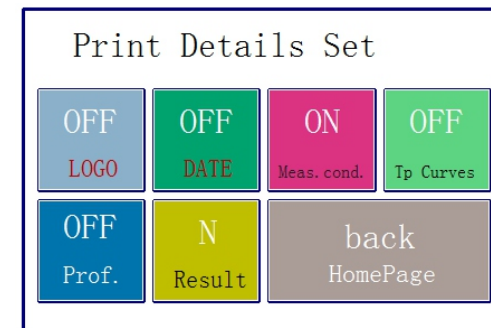

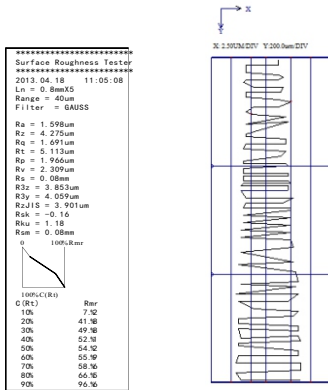
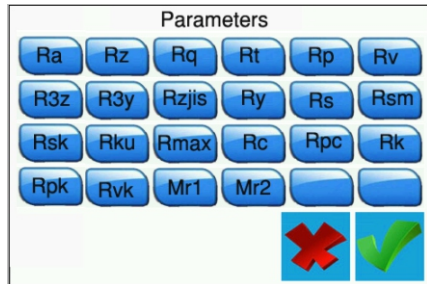

15 Data output to Excel

Data can be output to Excel by connecting with computer via bluetooth. set up Communication port, baud rate, data bit, parity check, stop bit, traffic control and other data.

1. The roughness meter is set to print mode, the baud rate is set to 115.2k, and bluetooth pairing is turned on Connect the instrument to the computer via bluetooth receiver.
2. Inset bluetooth receiver receiver to the computer , When the green light shows two flashes at the interval, the pairing is successful, the data can be directly transmitted to Excel by press "Enter" key .

Note: please note that the parameters of "result" is selected in "print details set", otherwise there will be no data output to Excel

16 Mobile APP

This instrument supports the wireless Bluetooth function, such as in the high altitude or pipeline operation is inconvenient to directly operate the instrument keys, Bluetooth remote operation function can be used. This mobile phone APP currently supports Android version 6 or more. Use mobile phone APP to control the instrument, please set the Bluetooth mode to data transmission mode, and turn on the Bluetooth power ,the connection password is 1234, It can be used when connect with mobile phone via bluetooth.

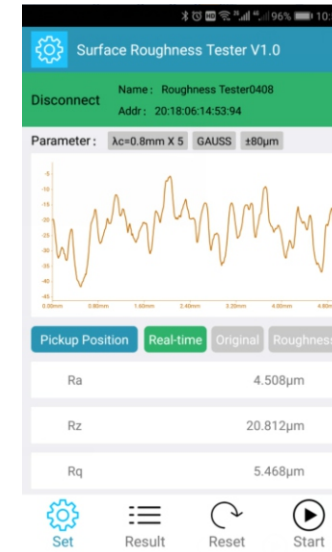

17 Dataview of software

Dataview of software can easily be waveform analysis and print measurement results uploaded to the PC machine. Use USB cable to connect computer data processing software to set the tester baud rate 921.6 k.

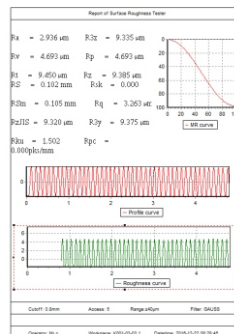
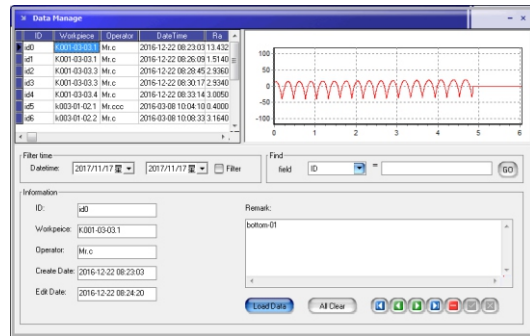
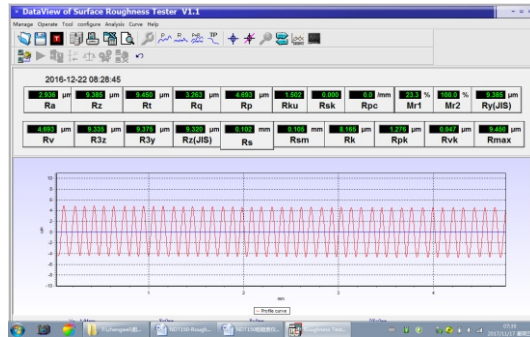

Options and Usage

1 Adjustable height support feet

When the measured surface of the workpiece is smaller than the bases of the instrument, the adjustable height support feet can be used as an auxiliary support to complete the measurement.

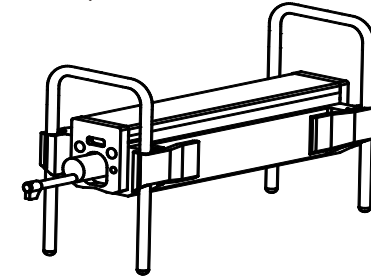

2 Height gauge adapter

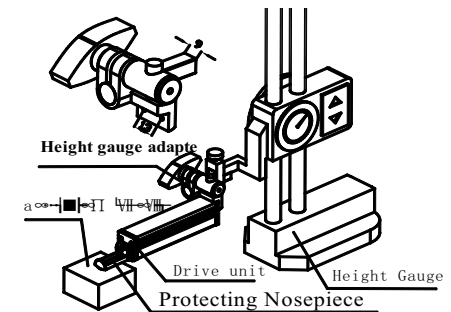

3 Extension rod (50mm)

Extension rod increases the depth for pickup to enter the part. Length of extending rod is 50mm.

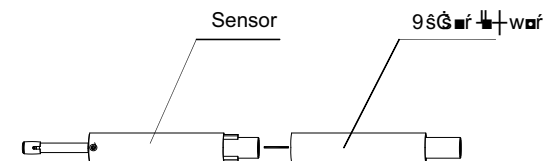

4 Groove Sensor

The groove sensor is the standard sensor of the roughness meter, and its demension are as follows:

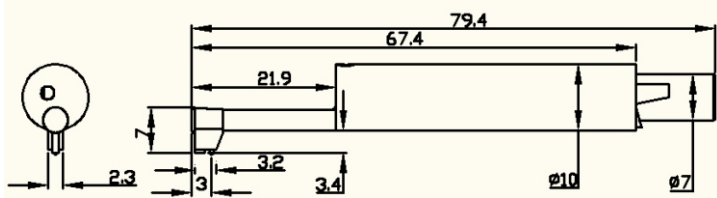

5 Small hole Sensor

Small hole sensor can measure the plane, inclined plane, cone surface, inner hole and other surface roughness.
Minimum measurable hole diameter: $\phi 5\text{mm}$
The use of small hole sensors must be installed on the measuring stand for measurement.

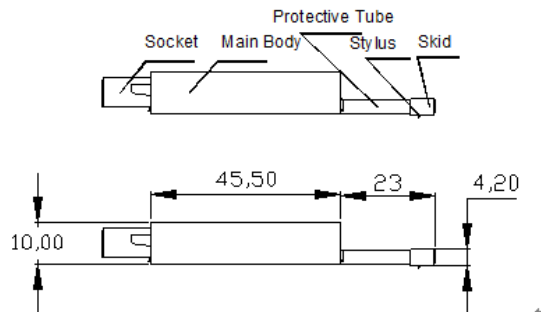

6 Extra small hole sensor

Using Extra small hole sensor, the inner surfaces of holes with radius more than 2.5mm can be measured. Refer to the following Figure for detailed dimension.

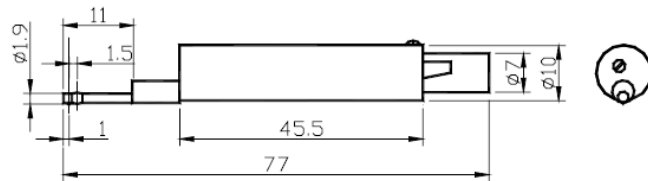

Extra small hole sensor operation method

The skid of the extra small hole sensor is behind the stylus. When it contacts the workpiece, the pickup position is first high and then low. The use of extra small hole sensors must be installed on the measuring stand for measurement.

7 Deep Groove Sensor

With deep groove sensor, it is possible to measure groove with width wider than 3mm and depth deeper than 10mm, or the surface roughness of step with height less than 10mm, Also can used to measure the planar, cylindrical used with platform. please see figure for detailed dimension.

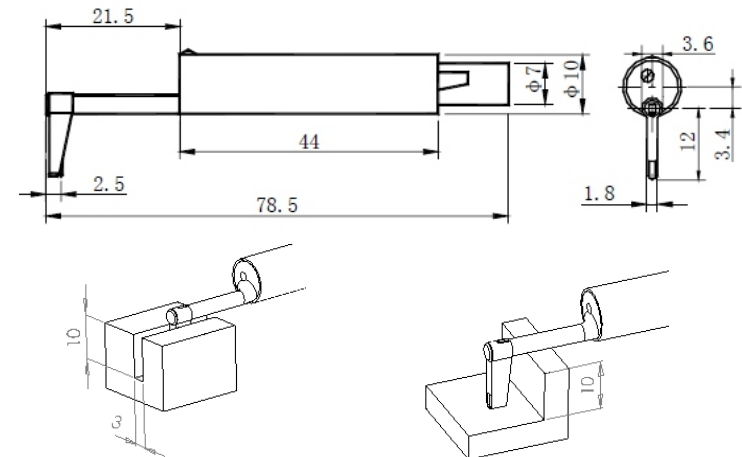

8 Support for flat surface

It is suitable for measuring the roughness of the measured object which is smaller than the roughness tester and the measuring plane is plane. The support can protect the sensor effectively.

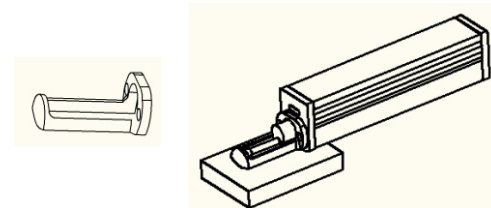

9 Support for cylindrical surface

It is suitable for measuring the roughness of cylindrical object which can not be measured directly. The nosepiece can protect the sensor effectively.

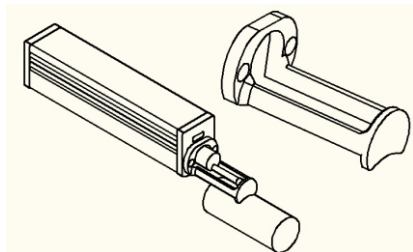

10 Bluetooth printer

The printer is a Bluetooth interface, and the roughness meter needs to be matched with the wave, the specific rate is set to 115.2k, and the bluetooth mode is set to "print" mode and turn on the bluetooth, the BT indicator lights up when the roughness instrument is connected successfully.

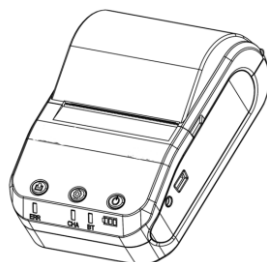

Note: in all of the above different measurement methods, it is necessary to ensure that the probe has a certain downforce. The touch pointer on the screen shall not prevail. The visual probe shall be parallel to the object under test.

Technical Parameter and Features

Name		Content
Measurement Range	The Z axis (vertical)	320μm (-160μm~160μm) / 12600 ± in (-6300 ± in~+6300 ± in)
	The X axis (horizontal)	17.5mm/ 0.69"
Resolution	The Z axis (vertical)	0.002μm/±20μm
		0.004μm/±40μm
		0.008μm/±80μm
		0.02μm/±160μm
Measurement item	Evaluation Parameter	Ra Rz Rq Rt Rc Rp Rv R3z R3y Rz(JIS) Ry Rs Rsk Rku Rmax Rsm Rmr R _{PC} Rk Rpk Rvk Mr1 Mr2
	Standard	ISO4287,ANSI b46.1,DIN4768,JISb601
	Graphic	Primary profile, Roughness profileload curves
LCD dimensions		3.5-inch 480*320
Filter		RC,PC-RC,Gauss,DP
The sampling length(lr)		0.25,0.8,2.5mm
Assessmentlength(ln)		Ln= lr*n n=1~5
Sensor	Principle	The displacement differential inductance
	Stylus tip	Natural Diamond, 90°cone angle, 5μm tip radius
	Measuring force	4mN
	Skid force	Less than 400mN
	Skid	Ruby Longitudinal radius 40mm
	Measuring speed	r=0.25, Vt=0.135mm/s
r=0.8, Vt=0.5mm/s		
r=2.5, Vt=1mm/s		
Return Vt=1mm/s		
Accuracy		No more than±10%
Repeatability		No more than 6%
Power supply		Built-in 3.7VLithium ion battery Charger :DC5V,800mA/5hou
Working Time		More than 50 hours
SIZE	Display unit	158×55×52mm
	Drive unit	115×23×27mm
Mass		About 500g(Display Unit + Dirve Unit + Sensor)
working Environment		Temperature - 20℃ ~ 40℃ Humidity < 90% RH
Store and Transportation		Temperature - 40℃ ~ 60℃ Humidity < 90% RH

Measuring Range

Parameter	Measuring range
Ra Rq	0.005μm ~ 32μm
Rz R3z Ry Rt Rp Rm	0.02μm ~ 320μm
Sk	0 ~ 100%
S Sm	1mm
tp	0 ~ 100%

General Maintenance

1 probe

- ◆ Any time swap probes are to be especially careful, careful not to touch the guide head and a stylus, because this is a key part of the whole instrument, to try to hold the probe guide head bracket roots (the front of the body) plug.
- ◆ To complete the measurement work, please timely probe into the box;
- 3. Please pay attention to protect the needle part measuring probe.
 - ◆ The probe's precision components, any knock, touch, fall off phenomenon may damage the probe, should try to avoid such situations.
 - ◆ The probe is a damageable parts, do not belong to the scope of warranty parts, only provide repair. In order not to affect the measurement work, users are advised to buy backup probe used for emergency.

2 Main Unit

- ◆ Pay attention to maintaining the Main Unit surface clean, often with a soft dry cloth to clean its surface.

- ◆ The instrument is a precision measuring instrument, should always be handled with care, to avoid the shock.
- ◆ Pay attention to add oil to maintain regularly every year to prevent internal wear.

3 Battery

- ◆ Always observe the battery prompt, when the low voltage, please charge.
- ◆ The charging time is 3 hours, try not to long time charge.

4 Standard Sample Plate

- ◆ The surface of a standard sample plate must be kept clean.
- ◆ To avoid scratches on the surface of sample area.

5 Troubleshooting

When the tester breaks down, handle the troubles according to measures described on Fault Information. If troubles still exist, please return the instrument to factory for repair. Users should not dismantle and repair the device by themselves. Returned instrument should be accompanied with sample plate attached. Phenomenon of problem should be explained.

Error message	Cause	Solutions method
After the boot, the display interface is about 1 minutes, turn off.	The cable plug is not tight.	Re insert socket
The sound of the motor can not be heard after turning on the tester.		
Touch screen failure	Touch Parameter loss	touch screen calibration In the main display interface, press ESC key for 6 seconds.
Motor error	Motor stuck	Reboot
Out of Range	1. The measured surface signal exceeding the measurement range 2. Placed away from the center of the stylus position	Increase Measuring range Adjust the Stylus position
No test data	After the boot does not measure.	The actual measurement: one time
Measurement Accuracy Out of Range	Set the parameter error Calibration data error	Set the parameter measurement Calibrate the tester

References

1 Terms

The instrument calculate parameters on the filter profile and the direct profile , all calculated in line with the GB / T 3505-2000 "Geometrical Product Specification(GPS) — Surface texture: Profile method——Term,definitions and surface texture parameters."

◆ Terms

Filtered profile: profile signal after primary profile is filtered to remove waviness.
 D-P (direct-profile): adopt central line of Least Square Algorithm.
 RC filter: analogue 2RC filter with phase difference.
 PC-RC filter: RC filter with phase-correction.
 Gauss filter: ISO11562.

◆ Traversing Length

● RC Filter

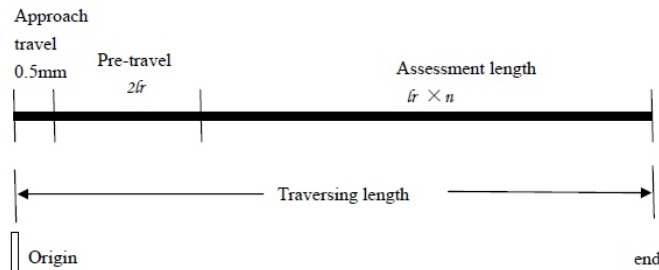

● GAUSS Filter

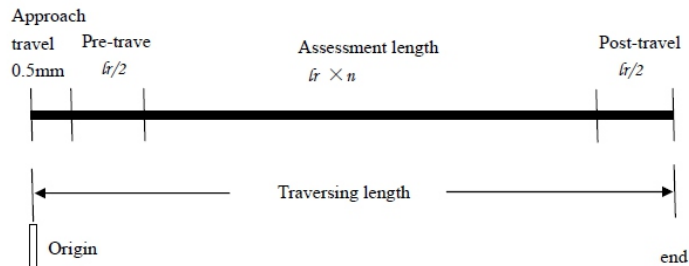

● PCRC Filter

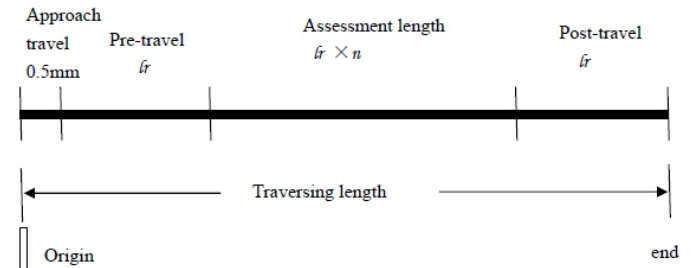

2 Parameters Definitions

◆ Arithmetical Mean Deviation of Profile Ra

Ra is arithmetic mean of the absolute values of profile deviation Z(x) from mean within sampling length.

$$Ra = \frac{1}{l} \int_0^l |Z(x)| dx$$

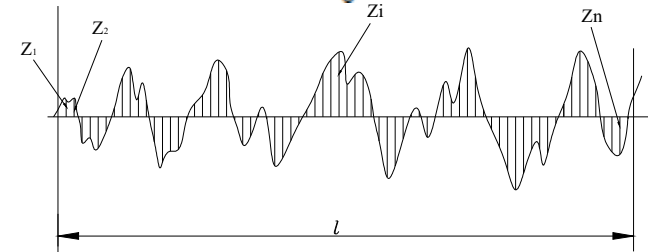

◆ Root-mean-square Deviation of Profile Rq

Rq is the square root of the arithmetic mean of the squares of profile deviation Z(x) from mean within sampling length.

$$Rq = \sqrt{\frac{1}{l} \int_0^l Z^2(x) dx}$$

◆ Maximum Height of Profile **Rz**

Rz is The sum of height Zp of the highest profile peak from the mean line and depth Zv of the deepest profile valley from the mean line within sampling length.

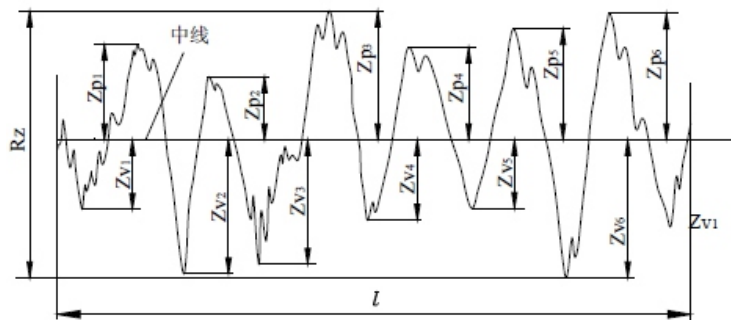

◆ Total Peak-to-valley Height **Rt**

Rt is the sum of the height of the highest peak Zp and the depth of the deepest valley Zv over the evaluation length.

③ Recommended table of the sampling length

Ra (μm)	Rz (μm)	Sample length λc(mm)
>5~10	>20~40	2.5
>2.5~5	>10~20	
>1.25~2.5	>6.3~10	0.8
>0.63~1.25	>3.2~6.3	
>0.32~0.63	>1.6~3.2	
>0.25~0.32	>1.25~1.6	0.25
>0.20~0.25	>1.0~1.25	
>0.16~0.20	>0.8~1.0	
>0.125~0.16	>0.63~0.8	
>0.1~0.125	>0.5~0.63	
>0.08~0.1	>0.4~0.5	
>0.063~0.08	>0.32~0.4	
>0.05~0.063	>0.25~0.32	
>0.04~0.05	>0.2~0.25	
>0.032~0.04	>0.16~0.2	
>0.025~0.032	>0.125~0.16	
>0.02~0.025	>0.1~0.125	