



www.insize.com

INSIZE



**IST-DCT SERIES
DIGITAL BOTTLE CAP TORQUE TESTER
OPERATION MANUAL**



Attention

- ◆ Operators should wear protection such as a mask and gloves in case pieces or components break away from the unit under test.
- ◆ Whether the unit is ON or OFF, DO NOT exceed the capacity of the gauge. NEVER exceed 150% of the rated capacity, or the torque sensor will be damaged. At 110% of the rated capacity, the display will flash a warning.
- ◆ Measure in line tension and compression torques only. DO NOT attempt to measure torques at an angle to the measuring shaft – damage to torque sensor and/or shaft may result.
- ◆ Do not attempt to repair or alter this instrument. Warranty will be voided and damage to the unit may result.
- ◆ Use and store within the stated temperature and humidity ranges, or damage and failure may result.
- ◆ If not using for extended periods of time, recharge it for every 2 to 3 months. Or remove the batteries to prevent potential battery leakage from causing product damage.

Description

There are four models of IST-DCT series bottle cap torque tester, the capacity and resolution is in table on the bottom of the product.

① Structure and dimension:

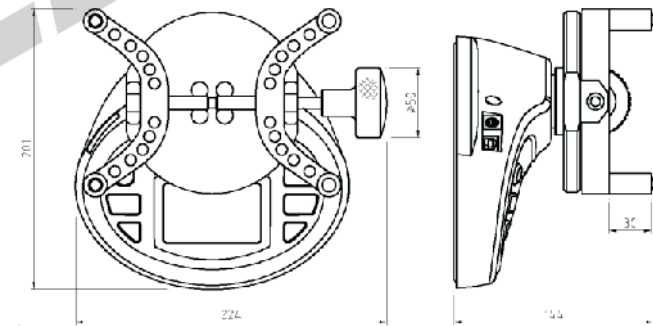

② LCD screen:

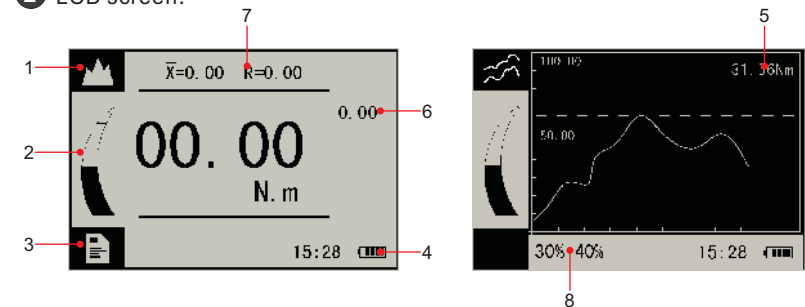

1. Test mode:

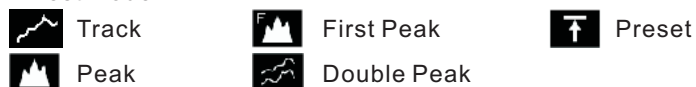

2. Analog bar and Direction Icon:

Indicates current position in whole capacity. When the bar enters the area enclosed by dotted line, means overload.



3. Storage/print setting:



4. Time and Power.

5. Torque value and Unit.

6. Statistics:

Save the five-point measurements in the Peak and First Peak.

7. Analysis:

X :average; R:variance criterion.

8. Prompt:

First Peak/Double Peak: Drop ratio;

Preset: under lower limit

between lower limit and upper limit

over upper limit

3 Function keys:

Power: Press for 2 seconds to power On or Off.

store/print: Through the system settings can be stored or print the current measured value;
In number input, change to another digit or item.

Zeroing/Exit: During Measurement, Zeroing;
In Menus: Back or cancel.

Up/Mode: In Menus: Moves selection up or increases the value;
During Measurement: Changes Test Mode.

Menu/Enter: During Measurement: Enter the menus;
In Menus, Select or Enter.

Down: During Measurement, Changes Test Mode.

Operation

1 Installation:

1. Please fix the cap torque tester on the workbench. See following installation dimensions on the bottom.

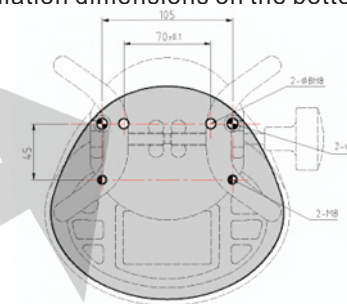



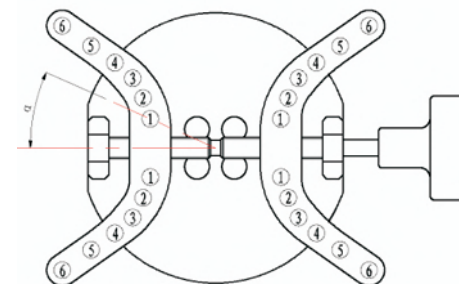

2 Clamping:

In order to better clamping effect, according to the size of the bottle, please choose the corresponding hole to clamp .

Position of the hole	Clamping Range	Angle α
1	Φ 19.5~44 mm	28.5~55 °
2	Φ 43.6~68.7 mm	35~55 °
3	Φ 66.8~101.9 mm	35~55 °
4	Φ 101.1~128.2 mm	35~45 °
5	Φ 123.8~156.2 mm	35~45 °
6	Φ 151.4~190 mm	35~45 °





- 3 Power on/off:
Press the power key for 2 seconds to power On or Off.
The indicator can identify the load cell. You should check the model whether it is you want. Check Battery Icon. If the power is low, should be recharged.
- 4 Testing:
After completion of the test preparation, testing can be done.
 1. Select Units:
The torque gauge has a variety of measurement units, select the appropriate unit of force.
 2. Select Test Mode:
This series torque gauge has 4 kinds of measurement test mode can choose.
 -  **Track:** The real time measuring mode, under this mode, press the zero key the torque gauge will be cleared (remove tare).
 -  **Peak:** Peak readings will not change until a higher value is measured. Under this mode, press the zeroing key the torque gauge will update the display immediately.
 -  **Preset:** The tolerance limits can be set for GO/NG measurement also. If you set the alarm on and a valid limit, The icon will be displayed for within limit, lower than lower limit or exceed upper limit.
 -  **First Peak:** In this mode, the gauge can capture the first peak value of force, when the force value decreased to reach the drop ratio. The drop ratio can be set in menus.
 -  **Double Peak:** In this mode, the gauge can capture two peak value of force, when the force value decreased to reach the drop ratio. The drop ratio can be set in menus.
 - 5 Zeroing:
Press zeroing key to clear the torque gauge in track mode for removing the tare.
 - 6 Storage/print:
Measured results can be stored in the torque gauge, so that you can review or print them later.
Under the measure interface, Press the key to save value measured, and the save icon will be displayed.

Menu

	Unit
Measurement	Group
	Test Mode
Memory	Storage Mode
	Delete All
	Delete Selected
	Delete All
	Print Selected
	Up load data
System	Display Mode
	Power Off
	Backlight
	Key Tone
	Language
	Date/Time
	Diagram scale
	Key Setting
	Default Setting
Information	
Calibration	



Basic operation

From the home screen, Press  to enter the Menu.

Press  or  can move selection.

Then Press  can enter the next layer of menu.

Press  can cancel the setting or exit.

In number input, press  or  can increase or decrease the number, and press  can change to another digit or item.

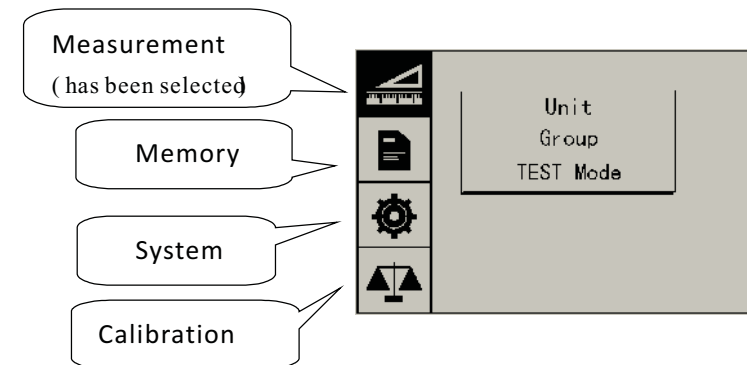

1 Measurement:

1. Unit:

The measuring unit can be selected under this menu. Different range models may have different unit selection capabilities.

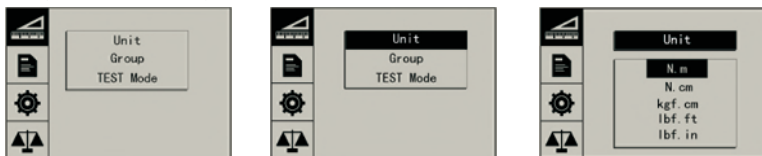

2. Group:

When several test samples need to be measured, the samples can be coded into groups. The range is 01-99.

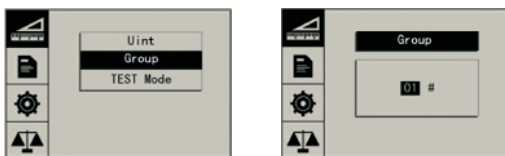

3. Test Mode:

Test mode can be selected. There are 5 kinds of mode: Track, Peak, Preset, First Peak and Double Peak.

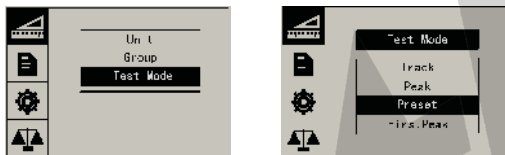

◆ Preset:

In the Tolerance menu, program upper and lower limit for GO/NG Measurement.

The upper limit value must be greater than the lower limit, and both limit value can not be greater than 110% of the rated capacity.



◆ FirstPeak/Double Peak:

With 5% increase or decrease in the drop ratio of the adjustment amount setting.

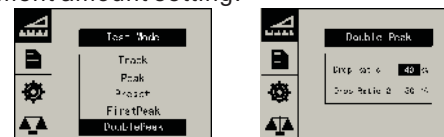

◆ FirstPeak/Double Peak:

With 5% increase or decrease in the drop ratio of the adjustment amount setting.

2 Memory:

In this menu, browse the data in memory or delete it/them and Print data.

1. Browse Data

The greatest number is the most recent data.



2. Delete data:

There are 2 methods to delete the data for restoring the memory.

Delete selected: Delete data in number range selected.

Delete All: Delete all data saved.

Before delete data, a warning window will pop up for further confirmation.

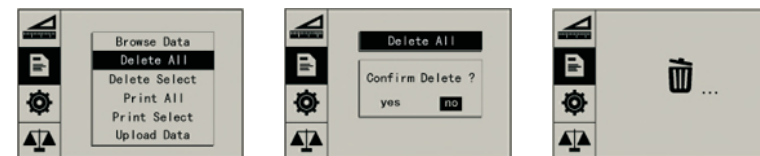

3. printing:

In Printing menu, you can Print Recent, Print Selected and Print All.



3 System setting:

Display Mode:

There are two display modes: Digital and Graphic.



Diagram scale:

The ordinate range selection When printing the chart.

There are 4 kinds of type: 20%,50%,100% of F.S.



Key Setting:

The key "Store/Print" is a multifunction key, It can be set as "store the current display value(Storage)" or "print the recent data (Print)". "Storage" is default.



Maintenance

- 1 When the battery are low, the icon will be displayed. The batteries should be charged immediately. Connect the gauge and the charger use the USB cable, and then connect the charger with AC socket to start charging. It takes about 3~4 hours for fully charging. You can also use other USB device (e.g. Laptop PC) to recharge the gauge.

2 Conversion:

	N.m	N.cm	kgf.m	kgf.cm	gf.cm	lbf.ft	lbf.in	Oz.in
N.m	1	100	0.102	10.197	10197.2	0.7376	8.8508	141.612
N.cm	0.01	1	0.001	0.102	101.972	0.0074	0.0885	1.416
Kgf.m	9.807	980.67	1	100	100000	7.233	86.7962	1388.74
Kgf.cm	0.0981	9.807	0.01	1	1000	0.0723	0.868	13.887
Gf.cm	0.0001	0.0098	0.00001	0.001	1	0.00007	0.00087	0.0139
Lbf.ft	1.356	135.58	0.1383	13.826	13825.5	1	12	192
lbf.in	0.113	11.299	0.0115	1.1521	1152.13	0.0833	1	16
Oz.in	0.007	0.7062	0.0007	0.072	72.008	0.0052	0.0625	1