

Morse taper (Tang type)

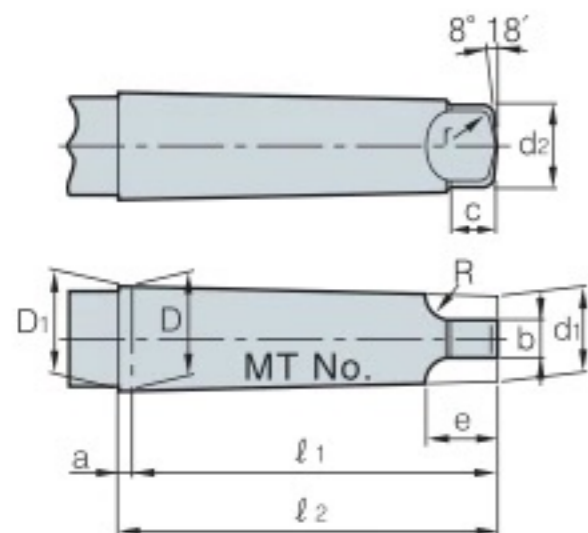

MTNo.	Taper	Taper angle (α)	D	a	D_1	d_1	l_1	l_2	d_2	b	c	e	R	r
0	$\frac{1}{19.212}$	$1^\circ 29' 27''$	9.045	3	9.201	6.104	56.5	59.5	6.0	3.9	6.5	10.5	4	1
1	$\frac{1}{20.047}$	$1^\circ 25' 43''$	12.065	3.5	12.240	8.972	62.0	65.5	8.7	5.2	8.5	13.5	5	1.2
2	$\frac{1}{20.020}$	$1^\circ 25' 50''$	17.780	5	18.030	14.034	75.0	80.0	13.5	6.3	10	16	6	1.6
3	$\frac{1}{19.922}$	$1^\circ 26' 16''$	23.825	5	24.076	19.107	94.0	99.0	18.5	7.9	13	20	7	2
4	$\frac{1}{19.254}$	$1^\circ 29' 15''$	31.267	6.5	31.605	25.164	117.5	124.0	24.5	11.9	16	24	8	2.5
5	$\frac{1}{19.002}$	$1^\circ 30' 26''$	44.399	6.5	47.41	36.531	149.5	156.0	35.7	15.9	19	29	10	3
6	$\frac{1}{19.180}$	$1^\circ 29' 36''$	63.348	8	63.765	52.399	210.0	218.0	51.0	19.0	27	40	13	4
7	$\frac{1}{19.231}$	$1^\circ 29' 22''$	83.058	10	83.578	68.186	286.0	296.0	66.8	28.6	35	54	19	5

(mm)