

Compound Sine Plate

Made of quality steel, hardened to HRC 55°-62°, angles 0°~60° capacity.

Minute angle step 0.2 built into the front gauge block roll eliminates steps in base plate.

Two end rails and one locking strap included
Tapped holes on the top.

Center distance of tools with 0.005 mm(0.0001")
V-612S within 0.008 mm(0.0003")



V-612S(M10 X 1.5)

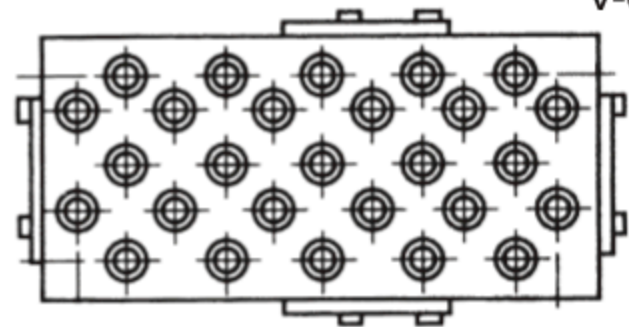

V-47S, V-66S M6 X 1.0

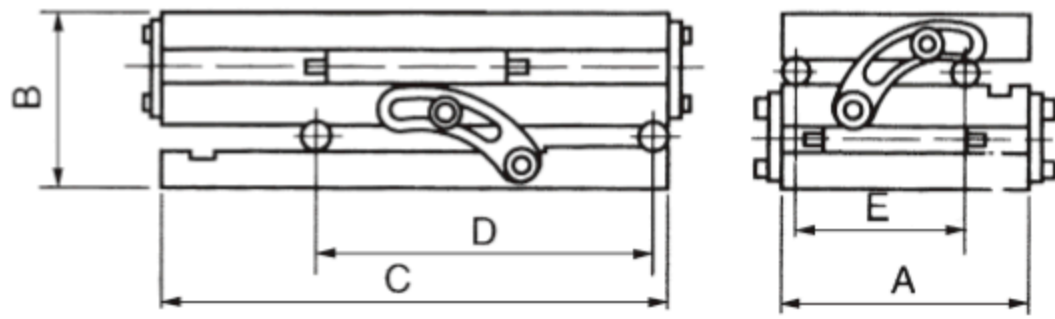

ORDER NO.	A	B	C	D	E	N.W (kgs)	CODE NO.
V-47S	100	100	175	100	75	9.9	2015-010
V-66S	150	150	150	100	100	12.4	2015-011
V-612S	150	150	300	200	100	23.7	2015-012