

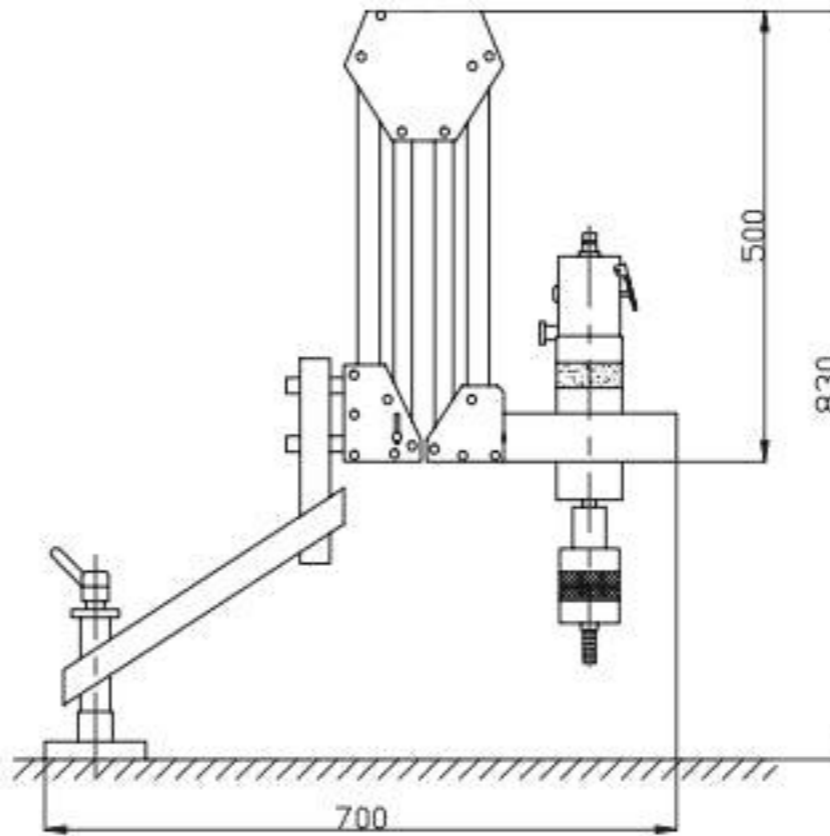

Small Arm Type Air Tapping Unit

HIGH TORQUE HIGH EFFICENCY EASY OPERATION



※Base not included

ACCESSORIES

- Air tapping spindle
- Parallel arm & Air combination
- Table mounting column
- Choose any six safety clutch tapping adapters
- Radial jib, increases arm reach by 500 mm

- Without stand plate
- Air pressure: 6~8 kgs / cm²
- VAT-08/12 series require: 5HP compressor
- VAT-16/20 series require: 10HP compressor

※ GUARANTEED FOR 3 MONTHS.

※ MUST INSTALL ON A STABLE / HARD SURFACE FOR PARALLEL WORK.

ORDER NO.	VAT-1408	VAT-1412	VAT-1416	VAT-1420	VAT-1422	VAT-1424
For Tap	M3~M8	M5~M12	M8~M16	M10~M20	M12~M22	M14~M24
	TC-312	TC-312	TC-820	TC-820	TC-820	TC-820
Speed (rpm)	700	400	250	200	200	100
Weight (kgs)	18.2	18.2	24.6	25.6	25.6	27.1
Work Range	Rmax 1400mm					
	Rmin 200mm					
CODE NO.	3404-415	3404-416	3404-417	3404-418	3404-418A	3404-418B