

TOOL MAKER VISE

- Made of SK material of J.I.S. specification.
- Hardened by heat treatment and precision ground.
- Squareness and parallelism are ensured to be within ± 0.005 mm / 100 mm.
- It can be used and kept its high precision while standing on its base, sides or extremity, for inspection use in stead of squares due to its extremely accuracy.
- Hardness: HRC $54^{\circ} \pm 2^{\circ}$

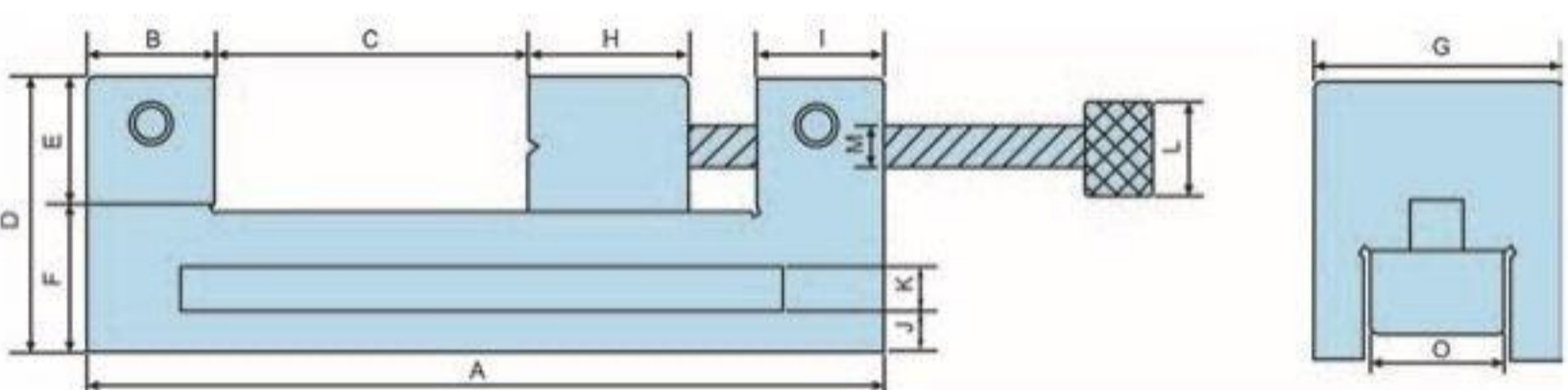

TOLERANCE ± 0.005 mm / 100mm

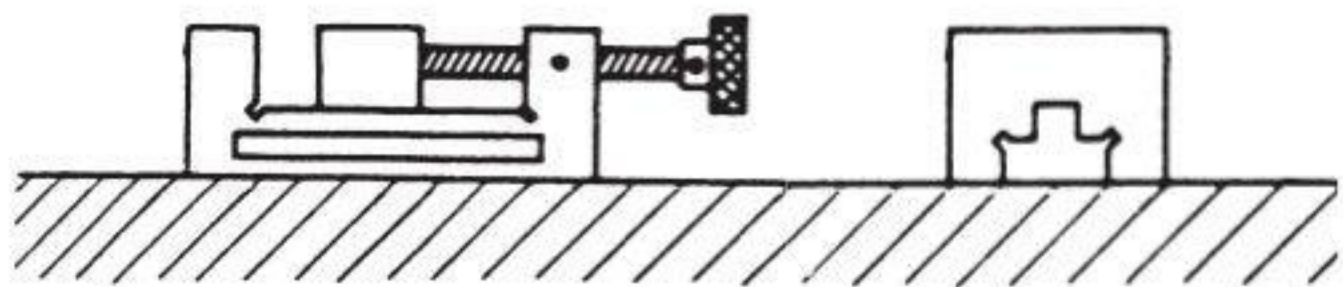

Unit:mm

ORDER NO.	MATERIAL	A LENGTH	B	JAW C OPENING	D	E	F	G	H	I	J	K	L	M	O	HEIGHT (mm)	HARDEN	WEIGHT (KGS)	CODE NO.
VDV-20	SK2	154	25	55	54	24	29	47	45	25	9.50	10.15	34.70	15.80	18.7	54	HRC $54^{\circ} \pm 2^{\circ}$	2.5	2003-020
VDV-25	SK2	175	25	75	60	29	30	62	44.80	25	10	10.90	39.60	18.95	26	60	HRC $54^{\circ} \pm 2^{\circ}$	3.9	2003-021
VDV-30	SK2	180	30	71	70	29	40	72	51.85	25	14	12.35	50.35	18.95	26	70	HRC $54^{\circ} \pm 2^{\circ}$	5.7	2003-022
VDV-35	SK2	250	35	121	73	38	35	88	55.40	35.55	10.80	11.60	54.85	25.35	30.20	73	HRC $54^{\circ} \pm 2^{\circ}$	9.2	2003-023
VDV-40	SK2	250	35	121	73	38	35	98	55	34.75	11.80	11.55	54.65	25.35	29.60	73	HRC $54^{\circ} \pm 2^{\circ}$	10.1	2003-024