

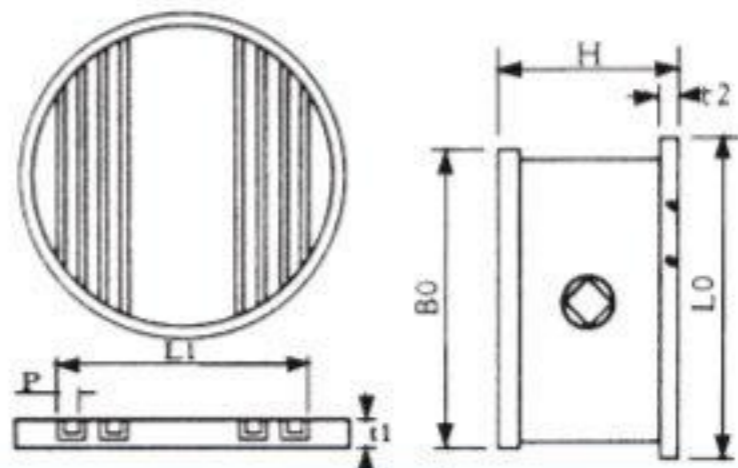

Round Type Magnetic Plate



ORDER NO.VGD TYPE

Magnetic field intensity:
Higher than 450 gauss

APPLICATION

Suitable for light cutting and grinding on lathe,
grinder, EDM and the Rotary Table.

Unit:mm

ORDER NO.	FACE PLATE			BOTTOM PLATE		POLE PITCH	HEIGHT	WEIGHT	CODE NO.
	B0	t1	L1	t2	L0	P	H	KGS	
VGD-06	150	21	101	18	200	9 (2+7)	78	9.8	2015-150
VGD-08	200		137		200			12.8	2015-151
VGD-10	250		191		250			20.2	2015-152
VGD-12	300		227		305			30.4	2015-153