

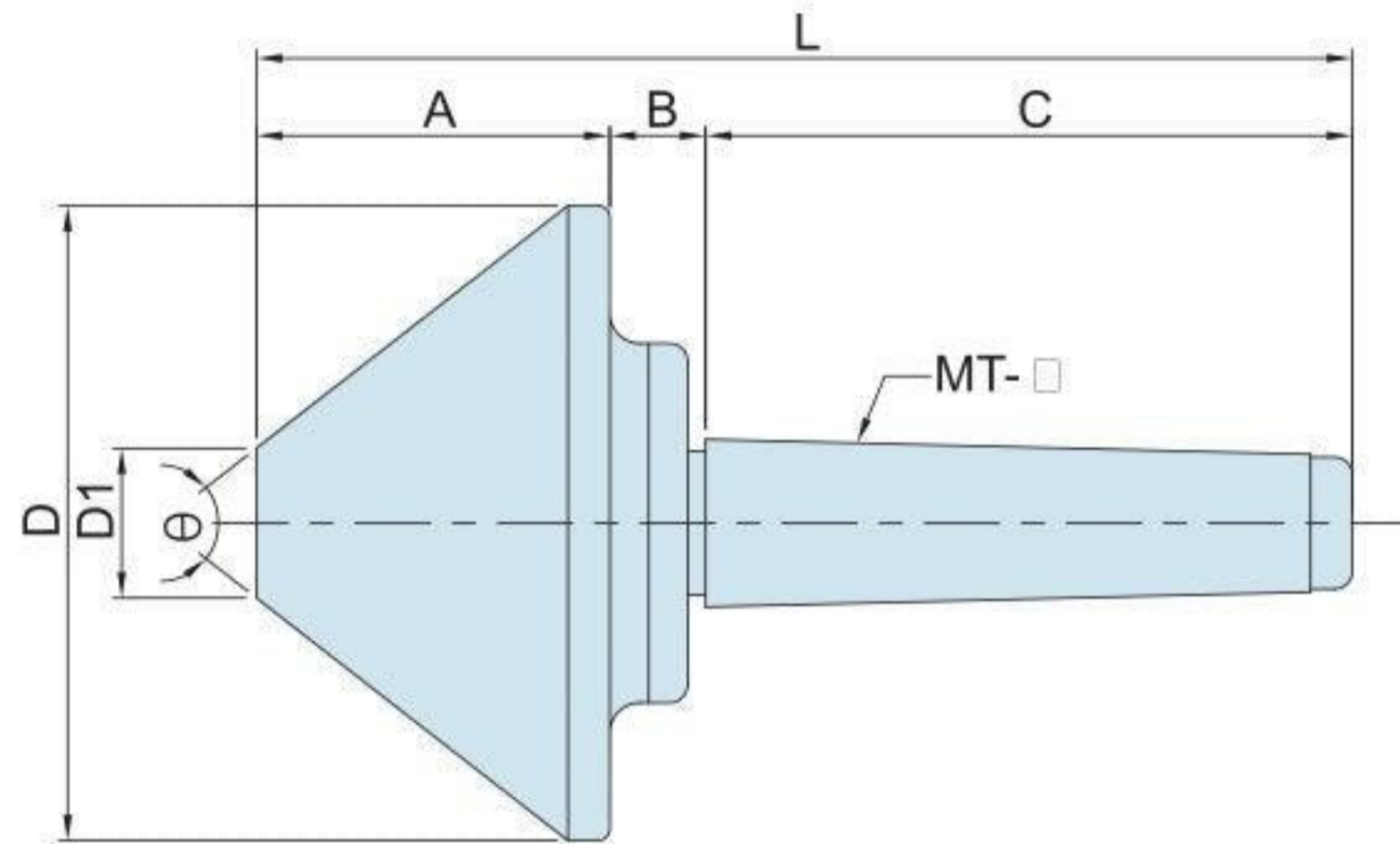

HARDEN PROCESS : HRC50°
 CONCENTRICITY : 0.005mm
 ROUNDNESS : 0.005mm
 MATERIAL : STEEL



※Suggested tailstock pressure under 6 kg/cm²

Unit:mm

ORDER NO.	SIZE MTxD	A	B	C	D	D1	L	Speed Max. R.P.M	θ	R.P.M 100 LOAD WEIGHT (KGS)	G.W. weight (KGS)	CODE NO.
VLC-422	MT2×2 1/2"	48	12	69	63.5	12	128	3000	60°	200	0.9	5001-070A
VLC-423	MT2×3"	56	12	69	78	19	138	2500	60°	400	1.3	5001-070B
VLC-424	MT2×4"	58	12	69	106	32	141	2000	70°	640	2.3	5001-070C
VLC-433	MT3×3"	52	18	86	78	19	156	3300	60°	400	1.6	5001-070
VLC-434	MT3×4"	59	16	86	106	32	161	3000	70°	500	2.8	5001-071
VLC-435	MT3×5"	71	12	89	128	35	173	1900	70°	960	4.2	5001-071A
VLC-436	MT3×6"	81	12	89	156	50	183	1900	70°	1200	7.3	5001-071B
VLC-443	MT4×3"	52	18	108	78	19	178	3300	60°	400	1.8	5001-072
VLC-444	MT4×4"	59	16	108	106	32	183	3000	70°	500	3.1	5001-073
VLC-445	MT4×5"	73	12	108	128	35	193	2000	70°	650	4.9	5001-074
VLC-446	MT4×6"	88	12	108	156	50	208	1900	70°	800	7.7	5001-075
VLC-448	MT4×8"	98	12	108	206	54	218	1500	75°	1300	15.4	5001-076
VLC-4410	MT4×10"	107	13	110	258	92	236	1000	80°	2000	24	5001-076A
VLC-454	MT5×4"	58	12	143	106	32	214	2000	70°	640	4	5001-077A
VLC-455	MT5×5"	73	12	136	128	35	221	2000	70°	650	5.8	5001-077
VLC-456	MT5×6"	88	12	136	156	50	236	1900	70°	800	8.6	5001-078
VLC-458	MT5×8"	98	12	136	206	54	246	1500	75°	1600	15.7	5001-079
VLC-4510	MT5×10"	107	13	143	258	92	264	1000	80°	2200	25.5	5001-079A
VLC-4512	MT5×12"	110	25	143	306	120	281	1000	90°	3000	37.5	5001-079B
VLC-466	MT6×6"	81	12	185	156	50	281	1900	70°	1200	12	5001-080A
VLC-468	MT6×8"	103	13	185	206	54	298	1500	75°	2000	15.8	5001-080
VLC-4610	MT6×10"	107	13	185	258	92	306	1000	80°	2500	28	5001-081
VLC-4612	MT6×12"	110	25	185	306	120	323	1000	90°	3000	40	5001-082