

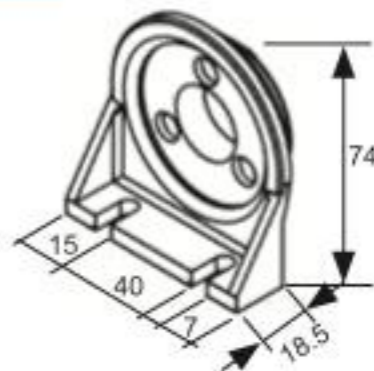

# Water-proof Reflector LED Lamp



**NEW**



BRACKET

- The products wide illumination range and brightness makes it suitable for areas requiring wide-range illumination. it is suitable for various machine tools when installed on different mounts, particularly machine tools within closed operating environments.
- Enclosure IP : IP67
- Wide illuminating range suit for various machine tools. Water proof & dust proof good for under ground environment.
- The protective cover is waterproof and dustproof, the lamp is conducive for subways, mines, and tunnel environments.

ORDER NO.	VOLTAGE	LAMP LENGTH	BULB	UMINATION DISTANCE	WEIGHT (KGS)	CODE NO.
VLED-W13	100V ~ 240V	448 mm	12W	0.5 m / 500 lux	2.2	1025-058
VLED-W18	100V ~ 240V	520 mm	12W	0.85m / 500 lux	2.5	1025-058A
VLED-W36	100V ~ 240V	734 mm	24W	1.10 m / 500 lux	3.5	1025-059