

Magnetic Holder

HANDLE TYPE



VML-80



VML-140

FEATURES

- Work is held and released very smoothly.
- Most suitable to move materials or semi-finished products such as black steel plate, flat iron and other materials etc.

HOLDING POWER

It depends on the attractive face, quality and thickness of material and clearance between the material and magnet.

MAXIMUM HOLDING POWER

Workpiece must be thick enough and the surface must be free of dust. magnetic attraction is best and with low carbon-soft steels.

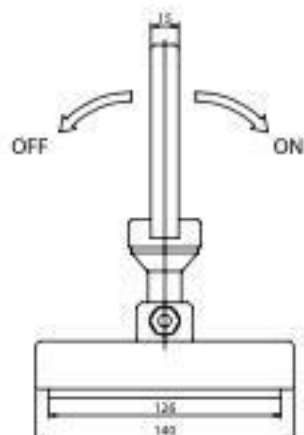
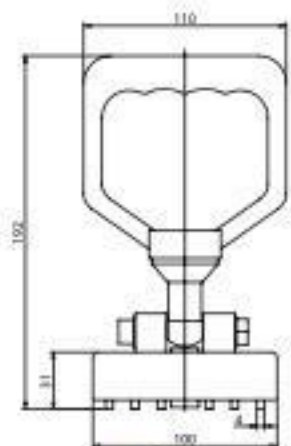

VML-150

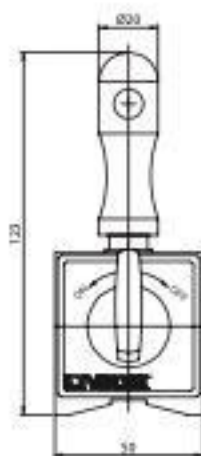

VML-80

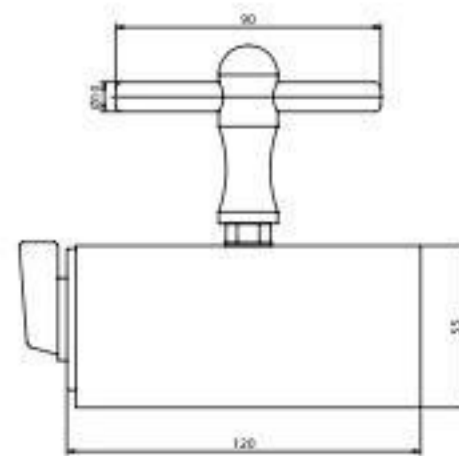
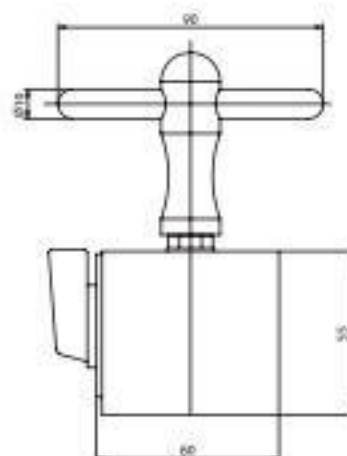

VML-140

Unit:mm



VML-150

ORDER NO.	CAPACITY	L	W	H	N.W (KGS)	CODE NO.
VML-80	80kgf	60	50	55	1.23	2018-054
VML-140	140kgf	120	50	55	2.2	2018-055
VML-130	130kgf	120	50	55	1.9	2018-053
VML-150	150kgf	140	100	192	2.5	2018-056

