

VRA-NT40



VRA-R8



VRA-TYPE

- Used on Vertical Milling Machine to make horizontal work.
- Rigidity constructed suitable for horizontal cutting.
- The clamping bushing to suit milling machine.
- Maximum spindle speed allowed right angle. 2000 R.P.M.

✂ Please notify the quill dia. when ordering

ORDER NO.	SUITABLE MILLING HEAD QUILL DIAMETER(mm)	WEIGHT (kgs)	CODE NO.
VRA-R8	85.725~86	12.5	1008-001
VRA-NT 30	85.725~86	13	1008-002
VRA-NT 40	85.725, 100, 105, 110, 115	18	1008-003

ARBOR FOR CUTTER INCH OR MERTIC SIZE

VRA-R8	R8-SCA1"	R8-SCB22
VRA-NT 30	NT30-SCA1"	NT30-SCB27
VRA-NT 40	NT40-SCA1"	NT40-SCB27

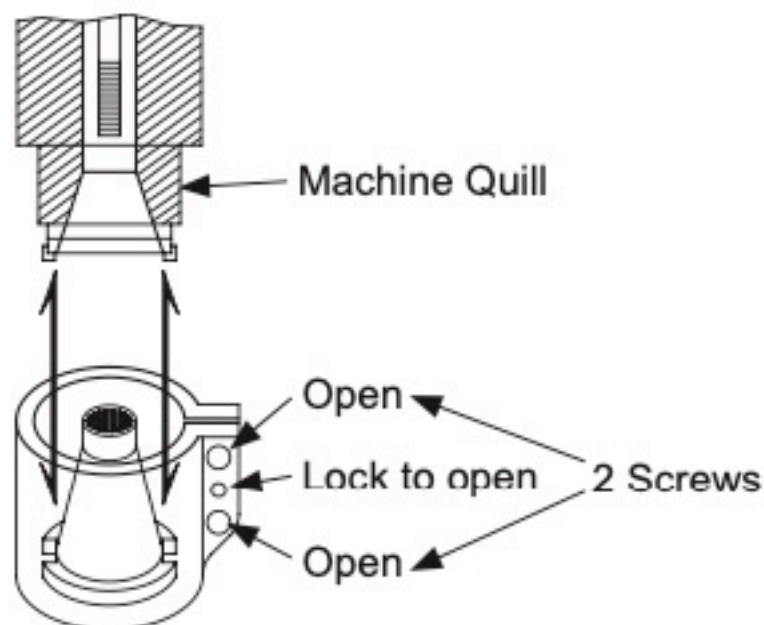
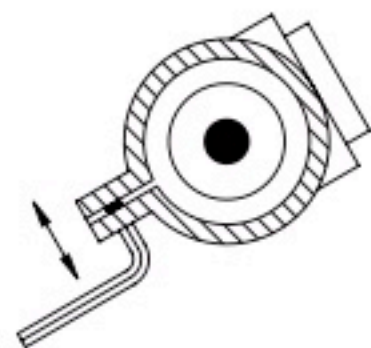

- Assemble with milling quill dia.

- Loose 2 screws to match with machine.
- Tighten 2 screws to fix on quill D.