

Eigenschaften:

- Robuste Ausführung, Korpus aus hochqualitativem Gusseisen; Backen, Basis und die restlichen Teile aus legiertem Stahl
- Induktionsgehärtete und geschliffene Stahlbacken-Einsätze
- Vertikale und horizontale Aussparungen zur Aufnahme runder Werkstücke
- Leitspindelabdeckung gegen Verschmutzung

Anwendung:

- Für Arbeiten mit Fräs-, Bohrmaschinen, etc.

Features:

- Ruggedly constructed with body and jaws made of high quality cast iron and other parts of alloy steel
- Steel jaw inserts induction hardened and ground, file cut for good grip
- Jaw inserts with vertical and horizontal recesses for clamping round workpieces
- Lead-screw completely covered to keep dirt out

Application:

- Designed for use with milling machines, drill presses, etc.

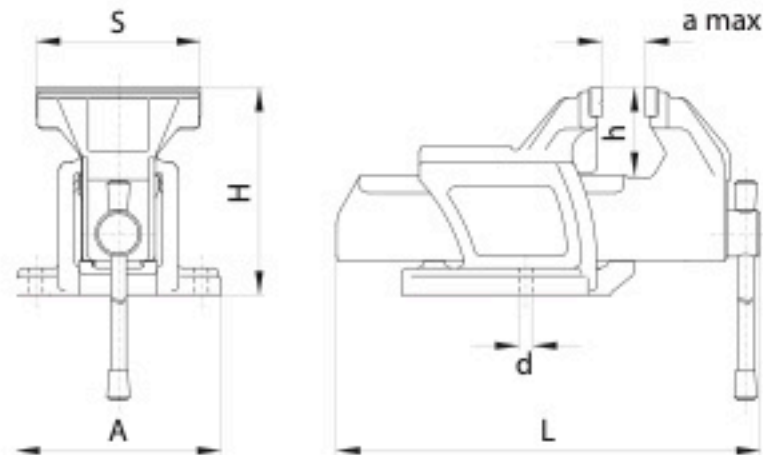
**SCHWERLAST-SCHRAUBSTOCK
HEAVY DUTY BENCH VISE****1250**

Passende Drehplatte
Matching swivel base



Typ
Type

1282

Seite
Page

245

Zubehör • Accessories 242-254

Artikel Nr. Code No.	Typ Type	S	A	H	L	a	d	h	Max. Spannkraft [daN] Max. clamping force [daN]		kg
● 321250030900	1250-63L	63	120	112	229	63	9	45	1.200		4,0
● 321250040000	1250-80L	80	137	137	280	80	11	58	1.800		6,6
● 321250150300	1250-100L	100	137	137	282	80	11	58	2.200		7,5
● 321250160500	1250-125L	125	156	156	323	100	11	65	2.600		10,5
● 321250170700	1250-150L	150	170	182	380	125	13	75	3.400		16,2
● 321250180900	1250-175L	175	190	202	434	150	13	90	3.800		23,0