

ATTENTION: NOT SUITABLE  
FOR 0.001MM DIAL INDICATORS

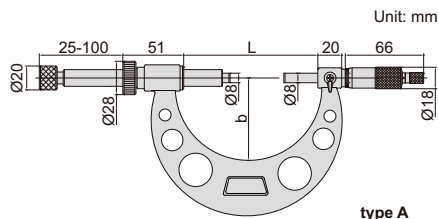

dial indicator  
is optional

3296-100A



type A

(mm)

Code	Range	Type	Accuracy	L	b
3296-100A	0-100mm	A	6 $\mu$ m	115	68
3296-200A	100-200mm	A	7 $\mu$ m	215	120
3296-300A	200-300mm	A	8 $\mu$ m	315	170
3296-400A	300-400mm	B	9 $\mu$ m	415	225
3296-500A	400-500mm	B	10 $\mu$ m	515	275
3296-600A	500-600mm	B	11 $\mu$ m	615	325
3296-700A	600-700mm	B	12 $\mu$ m	715	375
3296-800A	700-800mm	B	13 $\mu$ m	815	430
3296-900A	800-900mm	B	14 $\mu$ m	915	480
3296-1000A	900-1000mm	B	15 $\mu$ m	1015	530

## MICROMETERS WITH DIAL INDICATOR

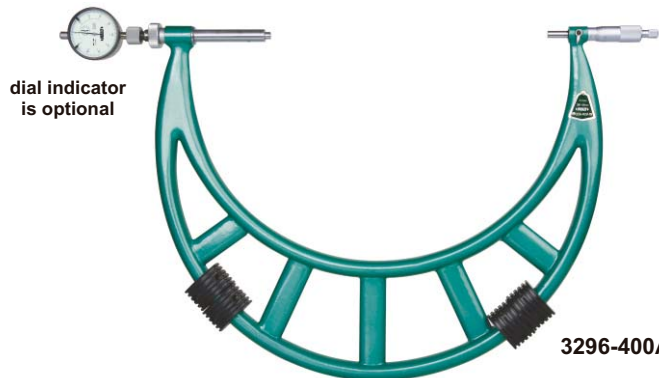

dial indicator  
is optional

3296-400A

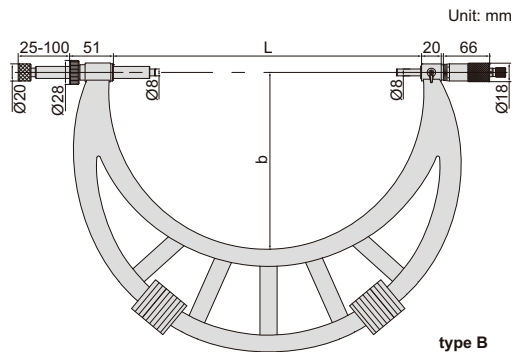

type B

- Meet DIN863-3
- Graduation 0.01mm
- Ratchet stop
- Carbide measuring faces
- Supplied with setting standards
- Optional accessory: dial indicators (graduation 0.01mm)  
digital indicators (resolution 0.01mm/0.0005")