

Countersink

PREMUS®

Cat. no.	P N/mm ²	M N/mm ²	K HB	S N/mm ²	N N/mm ²	
110180	<1000	<750	<250	Titanium	Copper, brass, Alu <600	Plastics
110195	<1200		<300			
vc = m/min.						
110180	18-28	4-10	8-20	4-10	10-80	10-80
110195						

HSS



coated

DIN 335

Form C

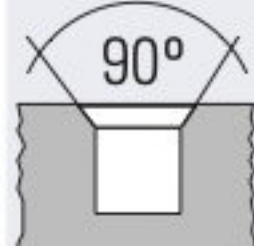

90°

Straight shank





Vc

Design:
 - with 3 cutting edges
 - radial relief ground

TiN coating: Universal coating for longer service life
TiAlN coating: High-performance coating for increased tool life, esp. in steel and cast iron materials

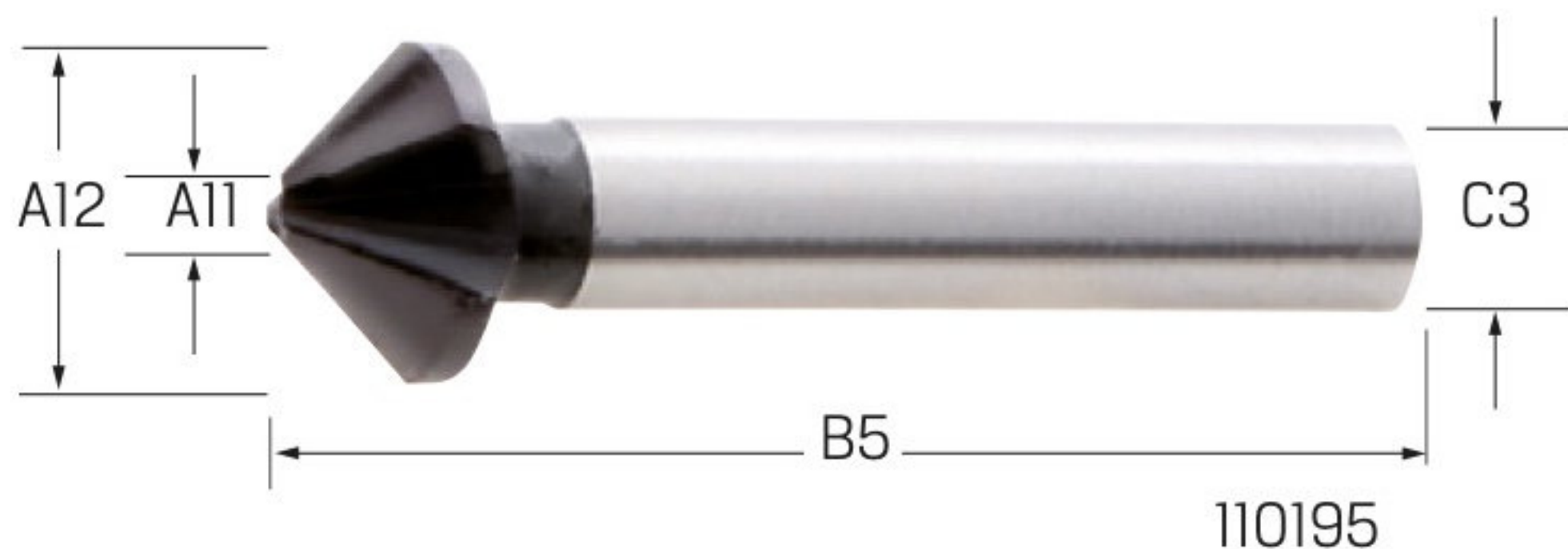

Item no.	110180 HSS, 90°, TiN	110195 HSS, 90°, TiAlN	A11 mm	A12 mm	B5 mm	C3 mm	f mm/rev
5,0	●	—	1,5	5	40	4	0,040 - 0,120
6,0	●	●	1,5	6	45	5	0,040 - 0,120
6,3	●	●	1,5	6,3	45	5	0,040 - 0,120
7,0	●	—	1,8	7	50	6	0,040 - 0,120
8,0	●	●	2	8	50	6	0,050 - 0,140
8,3	●	●	2	8,3	50	6	0,050 - 0,140
10,0	●	●	2,5	10	50	6	0,050 - 0,140
10,4	●	●	2,5	10,4	50	6	0,050 - 0,140
11,5	●	●	2,8	11,5	56	8	0,050 - 0,140
12,4	●	●	2,8	12,4	56	8	0,060 - 0,180
15,0	●	●	3,2	15	60	10	0,060 - 0,180
16,5	●	●	3,2	16,5	60	10	0,080 - 0,200
19,0	●	●	3,5	19	63	10	0,080 - 0,200
20,5	●	●	3,5	20,5	63	10	0,090 - 0,240
23,0	●	—	3,8	23	67	10	0,090 - 0,240
25,0	●	●	3,8	25	67	10	0,120 - 0,300
31,0	●	●	4,2	31	71	12	0,120 - 0,300